

3-24-2016

Airborne Directional Networking: Topology Control Protocol Design

Barry C. Geise

Follow this and additional works at: <https://scholar.afit.edu/etd>



Part of the [Computer Engineering Commons](#)

Recommended Citation

Geise, Barry C., "Airborne Directional Networking: Topology Control Protocol Design" (2016). *Theses and Dissertations*. 300.
<https://scholar.afit.edu/etd/300>

This Thesis is brought to you for free and open access by the Student Graduate Works at AFIT Scholar. It has been accepted for inclusion in Theses and Dissertations by an authorized administrator of AFIT Scholar. For more information, please contact richard.mansfield@afit.edu.



**AIRBORNE DIRECTIONAL NETWORKING:
TOPOLOGY CONTROL PROTOCOL DESIGN**

THESIS

Barry C. Geise, Maj, USAF
AFIT-ENG-MS-16-M-017

**DEPARTMENT OF THE AIR FORCE
AIR UNIVERSITY**

AIR FORCE INSTITUTE OF TECHNOLOGY

Wright-Patterson Air Force Base, Ohio

DISTRIBUTION STATEMENT A
APPROVED FOR PUBLIC RELEASE; DISTRIBUTION UNLIMITED.

The views expressed in this document are those of the author and do not reflect the official policy or position of the United States Air Force, the United States Department of Defense or the United States Government. This material is declared a work of the U.S. Government and is not subject to copyright protection in the United States.

AFIT-ENG-MS-16-M-017

AIRBORNE DIRECTIONAL NETWORKING:
TOPOLOGY CONTROL PROTOCOL DESIGN

THESIS

Presented to the Faculty
Department of Electrical and Computer Engineering
Graduate School of Engineering and Management
Air Force Institute of Technology
Air University
Air Education and Training Command
in Partial Fulfillment of the Requirements for the
Degree of Master of Science in Computer Engineering

Barry C. Geise, B.S.C.E.

Maj, USAF

March 24, 2016

DISTRIBUTION STATEMENT A
APPROVED FOR PUBLIC RELEASE; DISTRIBUTION UNLIMITED.

AFIT-ENG-MS-16-M-017

AIRBORNE DIRECTIONAL NETWORKING:
TOPOLOGY CONTROL PROTOCOL DESIGN

THESIS

Barry C. Geise, B.S.C.E.
Maj, USAF

Committee Membership:

Douglas D. Hodson, PhD
Chair

Kenneth M. Hopkinson, PhD
Member

Abstract

This research identifies and evaluates the impact of several architectural design choices in relation to airborne networking in contested environments related to autonomous topology control. Using simulation, we evaluate topology reconfiguration effectiveness using classical performance metrics for different point-to-point communication architectures. Our attention is focused on the design choices which have the greatest impact on reliability, scalability, and performance.

In this work, we discuss the impact of several practical considerations of airborne networking in contested environments related to autonomous topology control modeling. Using simulation, we derive multiple classical performance metrics to evaluate topology reconfiguration effectiveness for different point-to-point communication architecture attributes for the purpose of qualifying protocol design elements.

I give the deepest and most sincere thanks to my family for their steadfast and unconditional support.

Acknowledgements

I'm profoundly grateful to my military mentors, CAPT Matt Kercher, USN (ret.) and Col Mark Hoelscher, USAF, for inspiring me to realize my own potential. This would not be a reality without all the support they have provided me.

Also, I thank my undergraduate study wingman Mr. Brian Miller. Without him, I may never have gotten to where I am today.

Finally, I would like to extend a special thanks to the following AFIT faculty members: Dr. Douglas Hodson, who graciously agreed to guide me through this journey as my advisor. Dr. Kenneth Hopkinson, Dr. Gary Lamont, and Dr. Raymond Hill for teaching me how to analysis complex problems, which enabled me to streamline my focus.

Barry C. Geise

Contents

	Page
Abstract	iv
Acknowledgements	vi
List of Figures	ix
List of Tables	xi
I. Introduction	1
1.1 Motivation	2
1.2 Background	3
1.2.1 Fifth Generation Warfare (5GW)	5
1.2.2 Network Centric Warfare (NCW)	5
1.3 Directional Mobile Ad-Hoc Networks (D-MANET)	6
1.3.1 Multiple-Radio Architecture (MRA)	7
1.3.2 Smart Antennas	7
1.3.3 Pointing, Acquisition and Tracking (PAT)	9
1.3.4 Autonomous Topology Control (ATC) Process	10
1.4 Research Emphasis and Goals	11
1.4.1 Investigative Questions	11
1.5 Preliminaries	13
1.5.1 Simulator Survey	15
1.5.2 Model Types and Suitability	18
1.5.3 Mobility Model Survey	21
II. Fundamentals	26
2.1 Conceptual Layers in a Wireless Network	27
2.2 Characterization of the Wireless Channel	30
2.3 Message-Oriented Communication	31
2.4 Scheduling Environment Assumptions	32
2.5 Multiple Access Interference (MAI)	36
2.6 Directional Antenna Design Challenges	41
2.7 Medium Access Control (MAC)	45
2.7.1 Time-Division Partitioning	46
2.7.2 Directional Medium Access Control (DMAC) Protocols	51
2.8 Neighbor Discovery	54
2.9 Topology Reconfiguration	57
2.9.1 Optimization and Performance	58
2.9.2 Protocols and Design Considerations	59

	Page
2.9.3 Algorithms	60
III. Experiments and Results	63
3.1 Topology Control Experiment	63
3.1.1 Experiment Purpose and Goals	64
3.1.2 Design of Experiments (DoE)	64
3.1.3 Network Dynamics	65
3.1.4 Networked Effects, Growth and Adaption	66
3.1.5 Measures Of Performance (MOP)	66
3.1.6 Assumptions and Results Disclaimer	67
3.1.7 Simulation and Model Organization	68
3.1.8 Problem Formulation and Visualization	68
3.1.9 Analysis of Results	76
3.1.10 Experiment Conclusion and Improvements	79
3.2 Channel Assignment Experiment	79
3.2.1 Experiment Purpose and Goals	79
3.2.2 Assumptions and Results Disclaimer	80
3.2.3 Simulation and Model Organization	81
3.2.4 Problem Formulation and Visualization	81
3.2.5 Design of Experiments (DoE)	82
3.2.6 Analysis of Results	83
3.2.7 Experiment Conclusion and Improvements	85
IV. Future Work	87
4.1 Network Management and Data Routing	87
4.1.1 Network Identity	88
4.1.2 Join	90
4.1.3 Split and Merge	91
4.2 Protocol Performance Modeling and Evaluation	93
4.2.1 Layered Framework Design Concept	94
4.2.2 Practical Considerations	96
V. Findings and Recommendations	98
5.1 Parting Shots	99
Bibliography	100
Vita	114

List of Figures

Figure		Page
1	MRA example: four sectors; two transceivers	7
2	MIMO antenna array example by [14]	8
3	Adaptive antenna system by [15]	9
4	MIMO streams and users example by [16]	9
5	Four-node/eight-sector antenna example	10
6	Topology control process by [10]	11
7	Link reconfiguration timeline by [22]	13
8	Mobility model categories for MANETs by [43]	23
9	One node movement trace with an RWP mobility model by [41]	24
10	Wireless network layers	28
11	Tailored stack and data encapsulation example	28
12	4xComm architecture concept by [20]	29
13	Radio-to-router interface by [45]	34
14	Deliberative/reactive controller by [20]	35
15	Direction antenna pattern model by [69]	39
16	Directional antenna link modes by [69]	39
17	Contention example	42
18	Directional antenna design challenge examples by [67]	44
19	Time-division multiplexing by [72]	47
20	Timeslot sequencing example	50
21	Contention-based circular DMAC protocol visualization by [67]	52

Figure	Page
22	DMAC protocols taxonomy by [67] 53
23	Interference avoidance with power control by [67] 54
24	Hybrid-based single-channel DMAC protocol by [67] 55
25	Neighbor discovery coordination inspired by [84] 56
26	Protocol design decomposition example 59
27	Network stack with cross-layer control planes 60
28	Topology control taxonomy by [18] 61
29	3-way k-connected topology example 62
30	$X \times Y$ search space example 69
31	Convex hull shading example 70
32	Topology computation output visualization 74
33	ATC simulation visualization examples 75
34	ATC experiment results by block 78
35	Coloring algorithm output visualization 82
36	Domain collision visualization example 83
37	Channel assignment simulation visualization examples 84
38	Channel assignment experiment results by block 85
39	Duplicate network identifier example 92
40	Ambiguous network routing example 92
41	Simulation layers 95
42	Asymmetric antenna gain properties 97

List of Tables

Table		Page
1	Qualitative assessment by tool	18
2	Time to communicate (T_{comm}) parameters	50
3	Factor dimensions, complexity and levels	65
4	ATC experiment configurations	65
5	Random waypoint mobility model configuration	66
6	Software design and function	68
7	ATC experiment results summary	77
8	New and revised software	81
9	Channel assignment experiment configurations	83
10	Channel assignment experiment results summary	86

AIRBORNE DIRECTIONAL NETWORKING:
TOPOLOGY CONTROL PROTOCOL DESIGN

I. Introduction

Many existing DoD aircraft and weapon systems are developed using platform-centric top-down design approaches from high-level Operational Requirements Documents (ORDs). Unfortunately, ORDs inherently lack functional design details and allocated performance requirements needed to achieve robust multi-platform networking capabilities. As a result, there are often key performance parameter and specification gaps that leave the acquisition communities with significant programmatic challenges related to fielding timely and coalition-wide scalable networking capabilities.

This thesis provides an overview of state-of-the-art directional networking methods and autonomous topology control (ATC) approaches being investigated that could offer adaptable and optimized point-to-point (P2P) wireless networking solutions for the high-intensity contested air battlespace. A secondary goal is to provide the acquisition community with research to improve and support better defined networking and communication architecture requirements leading to faster enterprise-wide capability fielding.

Resulting from the unpredictable and dynamic structure of airborne directional MANET, our topology control screening design experiment showed that a universal best optimization is not possible. Additionally, the experiment showed that one type of performance optimization may come at the expense of other network goals. The upper and lower performance bounds of an autonomous topology control optimiza-

tion and management protocol are dominated by solution quality, communication architecture assumptions, and constraints applied at each layer. Consequently, this research explores each control theory sub-problem and available solvers to formulate a practical, yet viable, protocol design suitable for directional MANET tactical airborne networks.

1.1 Motivation

The ability of network control processes to make mission-aware trades embodies a wide spectrum from predictive to reactive artificial intelligence (AI) capabilities. For airborne directional mobile ad-hoc network (D-MANET) communication architectures, the desired solution quality vs. affordable level of adaption (or learning) is still an open research question, especially since a topology control process puts not just a computational load to derive a response to near continuous mobility changes and channel conditions, but a communication load as well to schedule and disseminate route updates reducing the already finite network capacity. To support future capability development decisions, we propose a simulation framework for cost-benefit analysis experimentation in terms of throughput-delay trade-off vs. communication overhead.

The “No free lunch” (NFL) theorem for control intuitively captures one of our key research goals, that is, for an airborne D-MANET to determine the trade-off between self-organizing and de-centralized topology control costs (in terms of computational complexity and message passing) vs. the resulting network performance gains. The NFL theory is defined as “The best control method is one in which the complexity of the control process must closely match the complexity of the operations, which reasons that the decision space is constrained by the amount of available information” [1]. Thus, given the complexities of airborne directional MANET and the fractional link

capacity (as compared to other domains), this research investigates the impact of communication effects (like efficiency, availability, and information uncertainty) to topology control decentralized process behaviors and link budget.

The topology control solution performance bounds dictate the design trade-space available to network applications. Efficient formulation of an optimal topology solution within this region is a complex problem, because the topology control protocol design must balance available network resources, stack protocol performance, and application demands. For example, a higher data rate might be achieved but at the expense of some delay; or if connectivity is safeguarded then available capacity may suffer.

1.2 Background

In the last decade, advances in embedded processors, sensors, communication and networking technologies have presented many new growth opportunities for cooperative P2P networked autonomous systems and wireless sensor networks, which have enhanced many military tactical mission areas by providing faster targeting and identification and through enhanced situational awareness capabilities. Contributing to air dominance, these capabilities enable the operational freedom to attack, and the freedom from attack.

To enable multi-dimensional air support and assured Command and Control (C2) in a contested air battlespace, proliferation of these capabilities to additional platforms is highly desired. Unfortunately, the role-out of inter-operable P2P communication capabilities suitable for contested environment has been slow due to cost, requirements consensus, and technical challenges [2]. In part this is due to the economic realities that have necessitated leadership to invest in multi-role aircraft over disparate systems to maximize logistic and force structure savings [3]. The increased

aircraft complexity contributes to higher research, development and capability integration cost. Currently, within the contested domain, many platforms are limited to intra-flight (small number of similar platforms) data exchanges, which do not support the synergistic concept of the “combat cloud” [4, 5]. The concept behind the “combat cloud” is the application of distributed networked operations, which extends the Fifth Generation Warfare (5GW) strategy theories and Network Centric Warfare (NCW) operational concepts described below. They provide insight and context to the diversity, complexity and multi-faceted aspects of the emerging informational requirements shaping development of the “combat cloud”.

In addition to the 5GW and NCW theories, the operational environment plays a crucial role in network architecture design. The contested air battlespace includes Anti-Access/Area Denial (A2/AD) threat systems and a hostile electro-magnetic environment. The concept behind the anti-access military strategy is that of stringing together relatively low-cost systems to nullify advantages or impose significant cost on any attempt to project power. Perhaps of greatest consequence to the warfighter is with regard to the ability to project expeditionary power, since A2/AD impacts freedom of movement. In 2013, the USAF Scientific Advisory Board (SAB) better defined the specific capabilities needed by directional networks operating within the contested air battlespace as: “...self-forming, self-managing directional tactical data link operating at higher frequencies, with the ability to make mission-aware trades involving capacity, latency, jam resistance, and detectability in real time”, which reaffirms the need for P2P networks to leverage adaptable and cognitive technologies to successfully support the requirements of processes working to transform data into actionable information supporting a decision making process. Additionally, the SAB findings imply a powerful observation about acquiring desired future networking capabilities, asserting that the acquisition of interoperable communication technologies

(datalinks) alone is unlikely to address all the challenges of networking dissimilar platforms [6].

1.2.1 Fifth Generation Warfare (5GW)

Shared by various military thinkers, the theory of 5GW describes an information-dominated warfare. It is further defined by the distinctive strategic abilities of a military to infiltrate and disrupt complex networked systems that lie at the heart of an opposing force (OPFOR) [7]. The focus of an engagement is not physical damage, but rather the destruction of an enemy through domination and disruption of their information systems. Simply put, to force an enemy to serve one's own interest. In addition, information warfare includes defensive and non-lethal options outside the traditional spectrum of warfare. Enablers include, 1) network-enabled systems and weapons, 2) spectrum dominance, 3) information superiority, 4) decision superiority, and 5) effects-based operations.

1.2.2 Network Centric Warfare (NCW)

NCW describes distributed networked operations, which are conducted by large numbers of diverse small units, rather than by small numbers of generally homogeneous large units. NCW is an enabler for several historically proven principles of war, like: mass, economy of force, maneuver, unity of command, and surprise. Intuitively we know, from the principle of mass, that an air wing is more powerful than that of any individual aircraft. However more data is not a substitute for intelligence, which is the product of data analysis and the reduction of uncertainty to acceptable levels. Thus NCW describes much more than just larger networks, but is a function of the sensor and communication technologies used, dissemination method, and use of information to provide a decisive warfighting advantage [7]. NCW supports 5GW

strategies by providing 1) the combatant with more discoverable, timely and actionable information about enemy capabilities, location and intent, 2) improved mobility and scalability of force, and 3) enhanced abilities to identify, process and comprehend critical elements of information related to a mission or engagement. Distributed networked operations are critical to the preparation for future conflicts, especially because emerging asymmetric threats are harder to detect and more difficult to characterize. Also, to counter a growing asymmetric threat spectrum ranging from rapid proliferation of long-range surface-to-air missiles (SAMs) to new applications of camouflage, concealment and decoy (CCD) techniques in domains like electronic-warfare and cyber [3].

1.3 Directional Mobile Ad-Hoc Networks (D-MANET)

Ad-hoc networks are comprised of nodes that can configure themselves autonomously to provide communication services without relying on pre-existing infrastructure. In the absence of fixed infrastructure, ad-hoc networks must adapt quickly to link-state changes (resulting from node mobility, node addition and deletion) and link-capacity changes (due to signal attenuation caused by free-space path loss, atmospheric or interference effects). One technology sub-class of ad-hoc networks is D-MANET, which utilizes beam-steering smart antennas to form P2P wireless links between each pair of nodes.

Since P2P links are less susceptible to interference and contention problems, this ad-hoc sub-class benefits from increased capacity [8]. Also, by avoiding transmission towards positions occupied by the OPFOR, this technology sub-class provides improved low probability of detection (LPD) and low probability of interception (LPI) properties. Additionally, the beam-forming attribute of the smart antenna extends range and enhances anti-jam (A/J) capabilities. The following sub-sections define the

basic components of a D-MANET communication architecture.

1.3.1 Multiple-Radio Architecture (MRA)

Multi-hop D-MANET are implemented using multiple-radios (see Fig 1 example) to form wireless mesh network (WMN) topologies [9]. The topology management controller (TMC), controls and optimizes the multiple-radio links to improve connectivity and path multiplicity between processing nodes, which increases reliability and scalability performance by lowering traffic contention [10, 11].

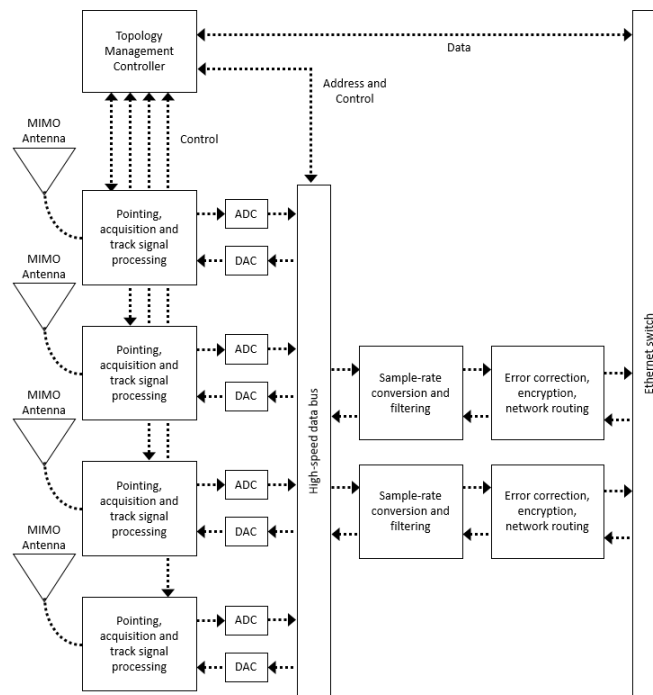

Figure 1. MRA example: four sectors; two transceivers

1.3.2 Smart Antennas

Through spatial multiplexing, smart antennas combine signal processing and multiple input, multiple output (MIMO) antenna arrays (see Fig 2) to achieve significant capacity gains [12]. Recent hardware technology advances offer substantial performance improvements related to adaptive beam shaping and steering, spread spec-

trum, multi-channel switching. The improved signal processing boosts wireless network performance by leveraging multi-array antenna advantages, such as multiplexing via multipath propagation, diversity coding and beamforming. As expected, this provides significant gains by a factor of 10-100 in wireless data rates and link reliability [13]. Additionally, calculated direction-of-arrival (DOA) estimates for received signals allow a receiver to track and locate a target's antenna beam while simultaneously nulling interfering signals by beamforming and shaping (see Fig 3).

This new technology radically departs from legacy standards, which are based on a small number of antennas in a sectored topology. With hundreds of antenna elements, MIMO reduces the needed radiated power by focusing the energy towards specific users using precoding techniques. Since less radiated power is required by directing the wireless energy to specific users, undesired interference is reduced, effectively increasing spatial diversity between transmitters (see Fig 4).

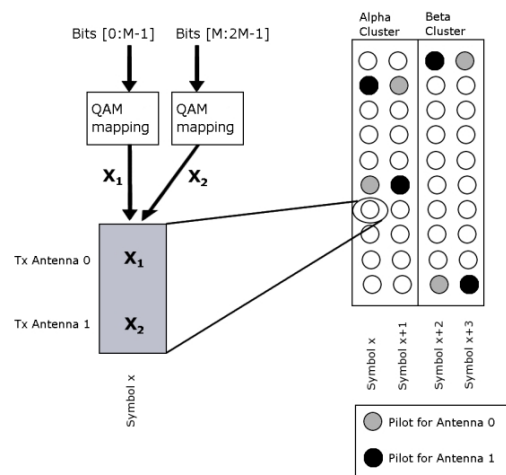

Figure 2. MIMO antenna array example by [14]

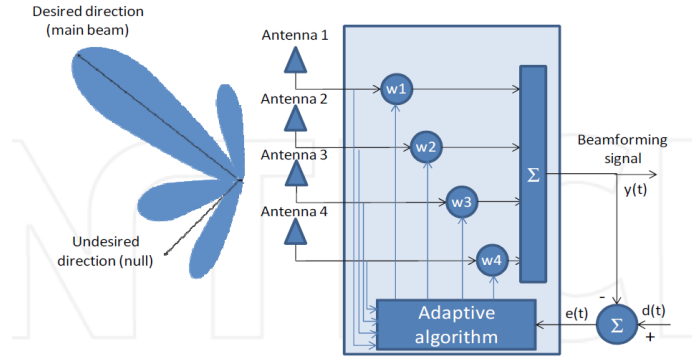

Figure 3. Adaptive antenna system by [15]

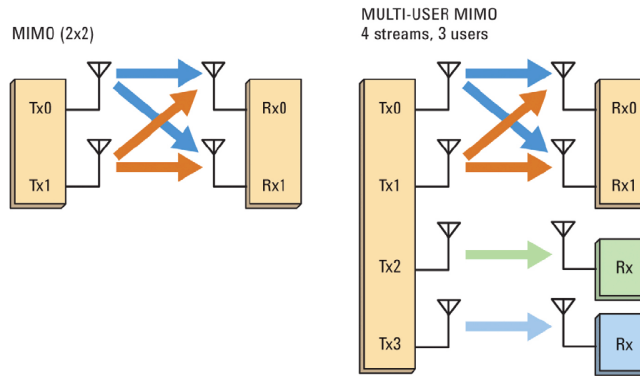

Figure 4. MIMO streams and users example by [16]

1.3.3 Pointing, Acquisition and Tracking (PAT)

Link maintenance requires information exchanges for neighbor discovery, tracking capabilities and topology control at rates that support aircraft movements [17]. Each airborne node is divided up into sectors (see Fig 5). The number of sectors required is based on aircraft fuselage blockage, needed performance and coverage. A four sector antenna-radio pairing implementation has been shown to result in a connected graph for more than 97% of all movement patterns [9]. The direction links must be created and then maintained to form a reliable connection.

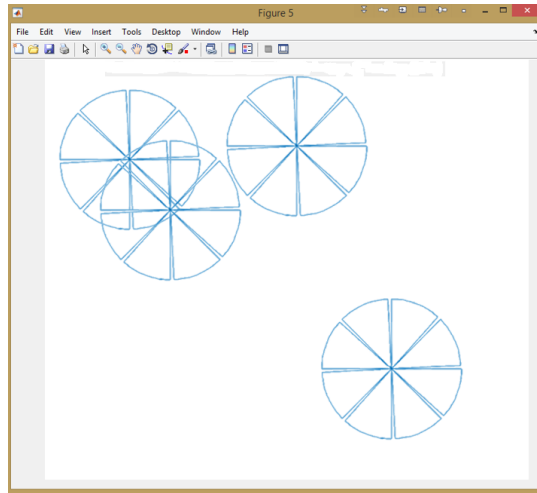

Figure 5. Four-node/eight-sector antenna example

1.3.4 Autonomous Topology Control (ATC) Process

The topology controller schedules, switches and coordinates each P2P link to adapt to mobility and topology changes. The five-step process includes: 1) link state assessment, 2) link state dissemination, 3) topology computation, 4) new topology dissemination, and 5) deployment and reconfiguration (see Fig 6).

Topology control involves not only the computation of new optimized topologies, but when and how to best adapt and migrate the physical links to the target topology without causing severe network disruptions. New link assignments can be either deterministically or opportunistically computed based on instantaneous availabilities [18].

Networks are frequently studied as weighted graphs where vertices represent the nodes in the network and the edges are the P2P links between them. The edge weights are the costs associated with each asymmetric link. So, the ATC problem becomes that of finding the sub-graph with the minimal total cost while satisfying the connectivity constraints.

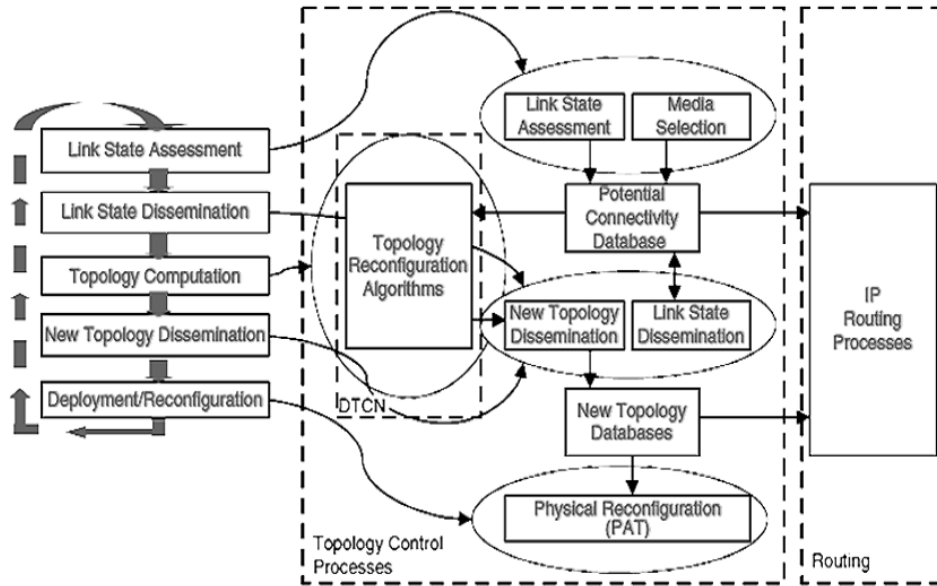

Figure 6. Topology control process by [10]

1.4 Research Emphasis and Goals

Our research is focused on autonomous topology control process and behavior analysis with respect to a specific MANET sub-class. Specifically we are concerned with tactical airborne directional MANET, which forms a complex system (or systems of systems). Some of the challenges related to the formulation of reliable and scalable networks include high mobility, multi-hop latency, finite bandwidth, limited transmission range, and intermittent connectivity [19, 20]. Our goal is to gain insight into a number of investigative questions related to technical feasibility and performance trends of augmenting currently fielded airborne D-MANET, with autonomous topology control capabilities.

1.4.1 Investigative Questions

The product of our research supports two different communities with different focus areas - that of acquisitions and academia. As a result, we must consider a broad range of network design and technical performance questions - some notional

examples are:

Network design questions

- What are the common services and design requirements needed to field self-forming, self-managing directional tactical datalink networks?
- What are implementation risks of autonomous topology control capabilities?
- What is the cost (in terms of bandwidth) of autonomous topology control?
- Can current intraflight datalink investments be augmented to support distributed operations? If so, what additional resources or upgrades are required?

Theoretical questions

- What number of interconnections (or channels) yields the greatest performance?
- What link selection method works the best?
- What computational method works the best?
- How reliable and scalable is the proposed approach?
- What optimization frequency yields the greatest reliability?

Although channel switching is beneficial to D-MANET communication, available research that includes the overhead (in terms of delay) of multi-channel switching is limited [21]. Also many protocols are developed with simplistic latency assumptions, which do not translate well to more practical and suitable real-world applications. Additionally, several researchers have found that resolving performance problems by making changes to a specific protocol layer is too narrowly focused and therefore highly problematic [9].

Flight test has found, as depicted in Fig 7, communication architectures with electronically steered beam antennas and time division multiple access susceptible to higher latency (in excess of 200 ms) during link acquisition/re-acquisition [17]. Since increased latency and jitter will affect protocols throughout the application layer, our protocol design process accounts for intermittent links and how to best minimize

and mitigate effects of physical layer disruptions due to multi-channel contention and beam steering changes in response to mobility. Simply put, the robustness of a topology control protocol needs to be discussed in terms of an imperfect channel state.

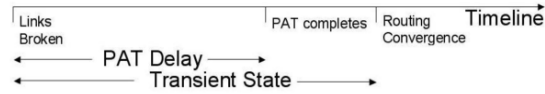

Figure 7. Link reconfiguration timeline by [22]

1.5 Preliminaries

There are many different model development approaches and strategies. We found the following model development approach by [23] best summarized our goals and needs:

“...must be kept simple enough to allow the derivation of meaningful theoretical results...it must be accurate enough to ensure that the findings obtained by using the model are useful in practical situations.”

Traditionally, tactical airborne radio networks are non-IP based and implemented with static resource allocation techniques in order to de-conflict access to the physical layer resources [7, 24, 25]. Frequently nodes are configured in advance, during a mission planning phase, with a specific configuration defining when and how the physical layer resources will be used to mitigate harmful interference. One problem with static configuration is physical layer resource utilization efficiency.

Inefficient resource utilization is especially problematic when information must be relayed over several point-to-point communication links as with D-MANETs. Although higher network connectivity supports broader coverage, a desirable attribute

in wireless sensor networks, the 60-100 ms of accrued latency per relay communication exchange garnishes both application and protocol performance [17]. With the move to scalable “combat cloud” multi-hop architectures, dynamic resource allocation techniques for sharing the physical layers’ resources must be implemented at the MAC layer.

Additionally, D-MANETs designed to be LPI/LPD compliant utilize short-duration transmissions (pulses) and spread-spectrum carrier signal modulation [26]. Short-transmission cycles are more difficult to detect, since signal detection equipment takes time to scan, analyze and identify emissions in the electromagnetic spectrum. Spreading the signal-in-space over a large amount of spectrum further improves the anti-jam and detection properties. Unfortunately, these additional design constraints increase transmitter-receiver dependence on tightly coupled frames for timing and position tracking synchronization. Consequently, packet sizes are much smaller (around 25-100 bytes) than other types of ad-hoc networks. Due to the smaller packet sizes and finite bandwidth typical of wireless sensor networks (WSNs), and in-turn D-MANETs, general purpose protocols often yield sub-par performance despite having proven performance in other types of ad hoc network deployments [21]. Thus, protocol designs that do not account for fundamental physical layer domain differences are at increased risk of erroneous performance conclusions.

Listed below are some of the salient features of this specialized airborne domain, in addition to, the use of directional antennas and mobility consent with maneuvering tactical aircraft.

- Frames for synchronization and tracking purposes
- Short transmission durations (with asymmetric duty cycle)
- Small packet sizes (25-100 bytes)
- Non-IP type headers and protocols
- Per node switch and router resources
- Per node multi-channel resources

1.5.1 Simulator Survey

Discrete-event simulation and network emulation tools have been widely leveraged to quantify theoretical performance of specific technologies and network protocols.

Advantages of using a simulator include the added flexibility to configure a variety of different parameters (i.e., system configurations), built-in tools to visualize problem and behaviors, tools for statistical gathering and analysis, and increased availability of community examples. Described in greater detail in Chapter II and IV, the modeling of scalable protocols for D-MANET topology control requires specialized self-organizing network services and parameter tuning within multiple Open Systems Interconnection (OSI) reference model layers (1-3) [27].

Communication and computation requirements may vary considerably for a decentralized control system during different phases of execution. A packet-level discrete-event simulator allows one to toggle the network topologies and parameters to see the effects they have on protocols, control plane traffic, broker services and middle-ware applications. For specialized D-MANETs, like airborne tactical networking within the A2/AD battlespace, simulating the aggregation of concurrent execution and constraint effects is crucial to upper-bound performance limit estimation, since channels, switches, routers, queues, protocols, broker services, and middle-ware all have their own set of parameters which vary over time due to dynamic network and environmental conditions.

Some of the most important parameters to model include packet error rate, delays due to link acquisition, switching and transmission, packet size, packet collisions, available bandwidth, queue sizes of routers, queuing method, and several broker service and topology control protocol specific parameters controlling state transition and timeouts.

There are a variety of open-source and commercial tools and frameworks available

to simulate digital wireless communications [28–33]. MANETs simulators, a digital communications sub-class, exhibit different features and models. Our simulator selection was guided by the research goals and the following criteria:

- Domain target
- Supported protocols and standards
- Level of detail required
- Level of object modification difficulty
- Number of nodes in the network simulation
- Available documentation and support

After a literature survey, we found the following simulators to be potentially well-suited to satisfy our research goals and supported within academic and research communities:

- NS-3
- OMNet++
- Simulink (a Matlab[®] extension)

NS-3 is widely-used open-source discrete-event network simulator built on C++ and Python. It's predecessor, NS-2 was originally developed by USC Information Sciences Institute to model wired networks with OSI model structures and later extended to include various IEEE wireless standards [34]. In addition to the comprehensive list of scalable and functionally validated behavior for wired and wireless communication domains, the simulator boosts a flexible event scheduler to allow function evaluation using arbitrary argument lists and emulation integration options [29, 30]. It supports “object aggregation” facilitating enhancement of existing objects, increasing re-use opportunities. Further, it supports large point-to-point topologies and includes 3-D node mobility models, in addition to, matrix propagation loss models supporting high-fidelity physical-layer models and cross-layer effects simulation. We determined the level-of-effort to utilize this simulator to be moderate-high due to the non-IP

problem formulation and D-MANET architecture dissimilarities.

Both an extensible and modular general purpose discrete-event simulator, the open-source OMNet++ suite offers a component-based C++ object library and framework [28, 35]. The simulator environment utilizes the popular open-source Eclipse-based integrated development environment (IDE) to provide users with an intuitive experience [36]. When used with the INET framework, it adds IP-based protocols and standards to support comprehensive network simulation like NS-3 [30]. Also, interface module can be modified to support non-IP type networks, in addition to, the enabling of multiple radios-per-node [37]. However, we considered Oversim (another OMNet++ based package) potentially a better match to D-MANET requirements, since it natively supports peer-to-peer and overlay network functionality. Regardless of the packages used, we determined the level-of-effort to be moderate-high due to many architecture dissimilarities requiring new development of debugging of several compound objects.

Simulink is a well documented and widely-used commercial tool for model-based design within the digital communication community [38]. Also, it boosts a great deal of hardware abstraction flexibility, in addition to, a comprehensive library of objects (blocks) similar to NS-3 and OMNet++. Although creating a one-off simulation environment should be avoided, we found Simulink's graphic-user-interface (gui) layer-hierarchy approach to model-based design very intuitive and efficient. Similar to the use of classes in object-oriented programming, the layer design process facilitates an iterative methodology to model development, verification and validation. Another design environment strength includes the use of ports between model layers, which is beneficial to behavior analysis of large and complex models and similar to the way OMNeT++ makes predefined connections between modules [33]. One drawback to the Simulink tool, is that it requires the SimEvents toolbox to support model-

ing of packet-based network effects, such as delay, jitter and packet loss. Further, it requires the Stateflow toolbox to graphically model combinatorial and sequential decision logic. It is also not open-source.

Both NS-3 and OMNet++/INET support large-scale network simulation, working to emulate the network stack with as much fidelity as possible. Also NS-3 supports hardware-in-loop simulation through interface emulation, which could be advantageous to future standards development and field experimentation. However, to satisfy near-term rapid prototyping goals we found the Simulink simulator to be best suited despite its drawbacks (see Table 1 findings). The highest weighted factors in our decision process included: 1) availability of applicable community models, 2) lowest development complexity, and 3) availability of tool documentation.

Table 1. Qualitative assessment by tool

Feature	NS-3	OMNet++	Simulink
Inherent complexity	Medium-high	Medium-high	Medium-low
Network scalability	High	High	Medium
Library/plugin utility	Medium	Medium-low	High
Intuitiveness of IDE	Unknown	Medium	High

1.5.2 Model Types and Suitability

A decomposition of our investigative questions in Section 1.4.1 reveals that nearly all the questions can be formulated in-terms of competing demands requiring selective and intelligent trade-off among the desired characteristics. The following Operation Research idiom concisely embodies the fact that models are by design inherently imperfect, because they must omit some of the in-effect limitless complexity of the real-world domain [39]:

“All models are wrong, but some models are useful”

Therefore, at each layer we focus on the choices about how to best represent the real-world task set using a surrogate model to minimize potential for incorrect inferences, while considering the relative costs of greater complexity against the gains it may offer. With regards to simulating autonomous topology control process behaviors and performance trends, the following sub-sections define the strengths and weakness of different models types.

Deterministic models

For deterministic models, the output of the model is fully determined by the parameter values and the initial conditions. These models are well suited for simple systems that can be described by a set of closed-form equations, where the numerical relationship between input and outputs does not include randomness or uncertainty. One advantage of deterministic models is that explicit traceability facilitating interdependency and low-level behavioral analysis, as compared to, probabilistic and stochastic methods described below which generally treat outliers as noise. Additionally other methods are not well suited for autonomous topology control behavior study, because networked performance is a highly skewed distribution [1].

Probabilistic models

In practice, practical implementations are likely to utilize aspects of probabilistic approaches, because they often perform better under limited information facilitating decreased network communication cost (or overhead). However, the challenge to design an effective probabilistic control method requires identification of all factors within the system, the uncertainties around each of them and their impact. Additionally, the distribution and impact of the responses must be well understood, especially

since the tails of the distribution are extreme events. For example, consider how the tails (the noisiest part of the probability distribution) mark extreme events, which are likely reliability events. Additionally, for systems like D-MANET ATC, determining the aggregate of probabilities that characterize the decision tree and resulting sequence of global and local events would be both complex and subject to error. Lastly, without availability of validated historical data that satisfies the scope of the network design, a probabilistic model would likely have limited utility. Thus, for our application, a probabilistic approach is not well suited. This becomes especially self-evident for our problem domain of airborne networking, since large scale flight test is often cost prohibitive.

Stochastic models

Stochastic models extend a deterministic framework to incorporate some inherent randomness. However, unlike a deterministic model with the same set of parameter values and initial conditions, a stochastic model yields a set of different outputs. Although there are many different ways to add stochasticity to a deterministic model, they are often constructed by modifying one or more of the terms in a deterministic equation with random draws from a representative probability distribution. To derive meaningful statistical results, simulations must be run a number of times to converge to a statistical estimate. Most advantageous to this class is that it combines the strengths of both deterministic and probabilistic methods to infer a computationally more efficient model at acceptable accuracy, while safeguarding the underlying interdependent and complex behaviors of interest. We consider stochastic model development for the deterministic formulations and present a logical next step towards hardware-in-the-loop simulation to demonstrate protocol maturity.

1.5.3 Mobility Model Survey

It is not uncommon for aircraft participating in distributed operations to have vastly different mobility rates, ranging from 25 m/s to 1200 m/s (Mach 3.5), and maneuverability capabilities. Further increasing the performance divide, is the emergence of hypersonic technologies that could potentially expand the window to 6860 m/s (Mach 20). Needless to say, intermittent and irregular connectivity amongst the nodes creates a creditable challenge towards topology control automation, which must be able to form and maintain time-varying asymmetric link topologies [40].

Research has shown that mobility model selection is a significant factor related to MANET protocol performance evaluation [40, 41]. For tactical communication systems, there are several mobility factors that contribute to realistic simulation of mission-based context scenarios, to include: [1, 23, 42]:

- Non-uniform deployments
- Heterogeneous aircraft performance
- Obstacles (threat avoidance)
- Tactical response
- Target loiter window
- Optimal paths
- Group (formation) movements
- Unit cohesion

The cost for inclusion of a greater number of factors is reduced model versatility [41]. This is due to a tighter coupling between a specific mission-based scenario and the underlying assumptions and behavior dependencies that the model is formulated on. For example, realistic tactical movements should include additional dependencies for a strike package commander who directs how other aircraft will approach the target and in which area to work based on tactical necessity, as compared to, the civilian transport model which assumes optimal routes to the destination. Another example, consider that a close air support mission which encounters high-terrain or

target obscuration that must be circumvented, would require model dependencies to invoke realistic velocity and/or altitude changes. Moreover, tactical mobility is often motivated air vehicle dependencies that cause airborne nodes to suddenly or unexpectedly depart the scenario, potentially due to expenditure of all ammunitions or fuel.

Alternately, a pragmatic approach to mobility modeling focuses on less specialized models that best fulfill the underlying mobility dependencies of the domain and scenario (i.e., distributed operations with the A2/AD battlespace). The following list of well-known protocol-independent metrics are often used to help quantify the degree of correlation between a real-world mobility pattern and that of an analytical mobility model. Consequently, since the metrics directly influence protocols performance, they have a strong correlation to network performance metrics, for example: throughput, delay, packet delivery ratio, and overhead [41].

- Degree of spatial dependence
- Degree of temporal dependence
- Relative speed
- Geographic restriction
- Number of link changes
- Link duration
- Path availability
- Number of neighbors

Due to absence of historical A2/AD operational mobility data, we reviewed a number of mobility model surveys specific to ad-hoc and tactical networks to help guide our selection with respect to the simulation goals [41–43]. At first, since today’s directional datalink capabilities are prevalent on 5G fighter aircraft [24], mobility representative of tightly-coupled heterogeneous group movements common to offensive-air engagements seemed advantageous. However, after giving consideration to the tenants of distributed operations, we concluded that a more realistic simulation will

include heterogeneous airborne nodes with differing capabilities and air vehicle performance. For example, consider that future conflicts within A2/AD threat zones are more likely to leverage alternatives to high-value wide-body surveillance assets due to their inherent vulnerability to long-range missiles and integrated air defense systems. As a result, to achieve equivalent early warning threat detection using LPI/LPD sensors, high-numbers of airborne nodes will be needed to not only maximize sensor coverage, but to maintain the persistent and survivable wireless sensor network. To achieve this, the force structure will be diverse and may consist of drones, unmanned aircraft, and other non-traditional ISR platforms - like 5G fighter and bomber aircraft. For this example, the mobility patterns would be more likely to resemble the movements of disparate units working to maximize sensor network coverage vs. tactical strike formations.

Thus, based on available literature, we selected the frequently used Random Waypoint Model (RWM). A benefit to RWM model use is that it, or a variant, are frequently used and relatively simple to implement, as compared to, models with dependencies - see Fig 8. The downside, since a RWM is memoryless, movements can result in abrupt direction and velocity changes (i.e., potentially unrealistic behaviors) - see Fig. 9.

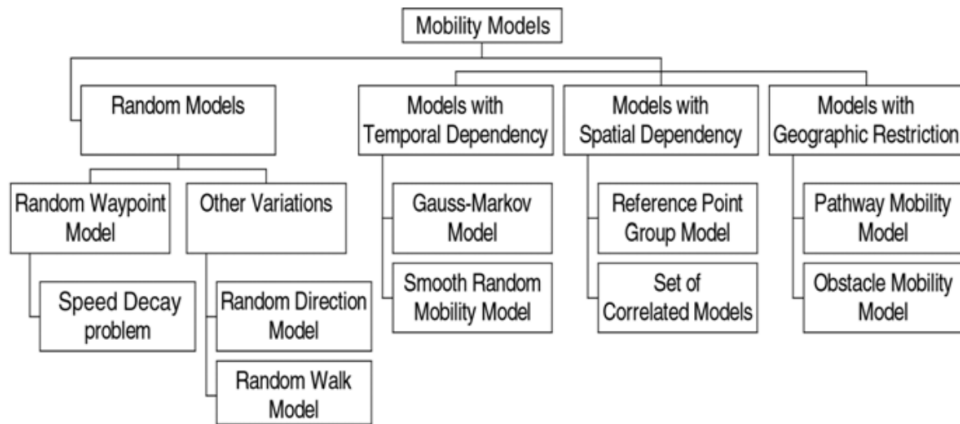

Figure 8. Mobility model categories for MANETs by [43]

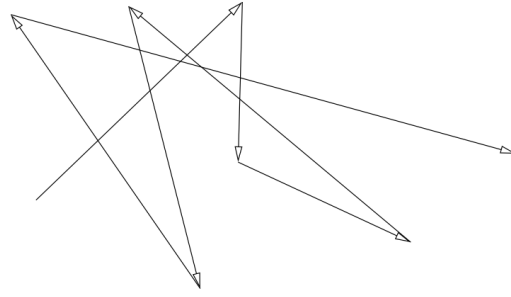

Figure 9. One node movement trace with an RWP mobility model by [41]

The RWM is a stochastic mobility model, in which nodes move independently to a randomly chosen destination with a randomly selected velocity. It includes parameters for a fixed number of nodes in a fixed-size rectangular search space. At the beginning of the simulation, nodes are uniformly distributed and then migrate into a non-uniform distribution - a characteristic of distributed operations [1]. Each node chooses a waypoint, then moves towards it with a speed randomly chosen from a user-defined range. After arriving at the waypoint, a new waypoint is selected, after a user-defined delay, using a heading offset from a user-defined range. Next, the process repeats for the duration of the simulation. Obviously, it is important to configure the user-defined parameters to match the airborne networking domain as closely as possible.

In fact, since our simulation goal is to model the highly-dynamic and erratic movements (i.e., the worst-case conditions for topology control) the RWM characteristics are favorable to memory-based models like the Gauss-Markov mobility model, which includes temporal dependencies [40]. A RWM property of particular relevance is called the density wave phenomenon, which cause the average number of neighbors for any given node to periodically fluctuate over time [43]. This property is especially advantageous to topology control protocol evaluation, since network-wide state

update messages are more prone to elicit undesired control loops or oscillations.

For all the reasons provided by [42], we encourage future work to repeat our operationally focused experiments with the Random-Waypoint Group Mobility model to observe topology control protocol behaviors under tactical mobility conditions.

II. Fundamentals

Unlike other MANET classes, airborne tactical networking is highly-specialized. It stands out from other classes of wireless communication systems due to the tight coupling of link layer technologies and protocol optimizations needed to reap maximum achievable throughput, which is frequently acquired at the expense of reduced interoperability [17, 24, 44, 45]. It goes without saying then that long-term enterprise impacts of optimizations like header compression, non-IP type protocols or stack layers need to be carefully evaluated before adopting.

Upfront communication architecture and protocol design choices are highly influential to the robustness and scalability of a network design, to include: topology strategies, routing and local forwarding policies, intra- and inter-domain hierarchy management, radio-to-router feedback mechanisms and processing latency guarantees at each layer, which all have network availability and scalability impacts [45, 46]. Thus, a tertiary goal of this research is to help identify potential architecture risk areas leading up to the successful transition of currently fielded 5G datalinks, forming intra-autonomous systems (AS), to a scalable hierarchy of intra- and inter-AS with self-organizing and autonomous topology control capabilities.

The design of a multi-channel/multi-hop topology control protocol stems from the efficiency at the physical layer, since the latency and bandwidth of the network are the underlying performance bottlenecks of this communication system sub-class [47]. Consequently, our simulation encompasses both the physical and logical control elements and reconfigurability of network topologies. The following sub-sections better describe some of the underlying wireless communication system properties, like: link loss, interference, contention, topology, synchronization, bursty traffic, message passing cost, etc.

Warfighter takeaways:

- *Commercial IP-type protocols are not well suited for airborne D-MANET*
- *Minimal evidence of key enabling technologies in relevant environment*
- *Enabling ATC protocols not likely to be developed by the civilian sector*
- *Multiple new purpose-specific routing protocols may be needed*
- *5G aircraft cooperative avionics architectures could usher in new, more efficient, and better performing spatial-aware protocols*

2.1 Conceptual Layers in a Wireless Network

Most legacy tactical airborne networks employ non-IP type enabled radio-technologies [17]. Compelling, but controversial reasons for non-standard layer models include [19, 48, 49]:

- Physical layer parameter optimizations for mobility
- Protocol efficiency
- Cross-layer feedback support for network services

Some of the potential advantages of non-standard stack include: 1) improved throughput, 2) faster stack traversal, 3) decreased message passing costs in terms of latency, and 4) improved packet header efficiency. A non-standard wireless communication stack is similar to a five-layer TCP/IP stack (see Fig 10), in that, each layer performs some predefined functions [50]. Also, all airborne nodes utilize identically layered stacks and each stack utilizes standard upward and downward interfaces.

Functions allocated to each layer include:

- Application layer: Cooperative command, control and communications processes spanning multiple tactical units (aircraft).



Figure 10. Wireless network layers

- Transport layer: Packet ordering, forward error correction, data flow and congestion control.
- Network layer: Distributed protocol stack that includes route management, traffic control and network management.
- Datalink layer: Medium access and logical link control; together they provide radio resource management, error control, power control, rate allocation, etc.
- Physical layer: Signal modulation, transmission and reception over the propagation channel.

Since each additional layer works independently with its own headers, the ratio of overhead to information content can be very high. Thus, the amount of overhead bits transmitted over the physical media in comparison to the information bits is exceedingly costly for bandwidth constrained airborne applications. Therefore, a non-standard protocol stack may eliminate one or more encapsulation layers to reduce header overhead (as illustrated by Fig 11).

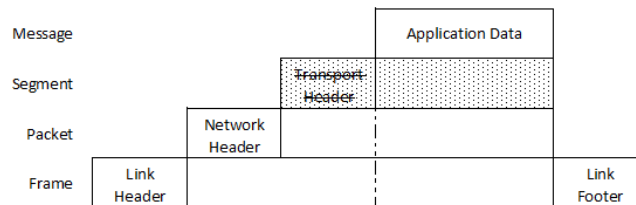

Figure 11. Tailored stack and data encapsulation example

Unlike wired networks, one of the unique challenges of directional MANET is to form a stable control plane operating over dynamic interconnections subject to disruptions due to beam pointing and link switching failures. A holistic D-MANETs architecture concept relies on an in-band multi-hop control plane (similar to the IP-based “Orderwire” network overlay in Fig 12) to make possible automated control and self-organization network capabilities. Alternative frameworks leverage back-channel communication (or secondary, non-directional wireless networks) to provide a stable control plane, which is not suitable for the A2/AD domain [51].

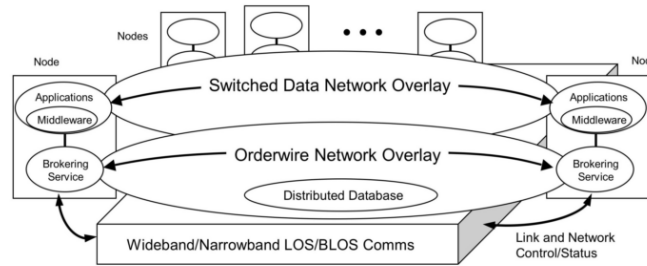

Figure 12. 4xComm architecture concept by [20]

A decentralized control plane provides a dedicated transport mechanism for nodes to coordinate their local decisions and actions to collectively establish a connected topology. Without a control plane, nodes are only aware of their directly connected P2P neighbors. To maximize topology control protocol performance and safeguard network operations, total control traffic must not exceed a throughput allocation reservation [52]. However, setting the bandwidth allocation too low may result in a network topology that never stabilizes. Alternatively, by setting the allocation too high then there is rise to the concern that the entire link bandwidth could be spent on the exchange of control packets.

Especially for multi-hop communication patterns, packet scheduling is a significant factor towards providing quality-of-service guarantees [50]. In addition to selecting the

appropriate packet scheduling algorithm, most topology control architecture concepts rely on highest-priority queuing to minimize packet scheduling latency. Consequently, this decreases the effective bandwidth for other competing applications and network services.

2.2 Characterization of the Wireless Channel

Our communication architecture research interests are formulated around a deterministic model developed by Mr Trevor Bosaw for the Massachusetts Institute of Technology (MIT) Lincoln Laboratory. It was developed to explore the basic functionality characteristics of the Multifunction Advanced Data Link (MADL) - a directional P2P K-band waveform with linear network topology fielded on the fifth generation Joint Strike Fighter [24].

The MADL model provides the physical and basic packet services appropriate to a direction (or P2P) MANET sub-class to enable suitable distributed protocol design. Per review, we observe that the communication services and lower-layer properties (as described in Section 1.4) can have great impact on ATC protocol design scalability and behavior attributes.

Although the author notes that any results of the model should not be considered representative of MADL due to, in part, several unimplemented dynamic behaviors (see [53], Fig 6), the fundamental performance attributes of this class include a high-sensitivity of bit-error-rate (BER) to noise (see [53], Fig 12-14), which underpins the importance of accurate channel contention modeling. Additionally, the latency-per-packet vs. load results (see [53], Fig 21-24) reinforces the significance of minimizing timeslot partitions to conserve channel efficiency and the importance of efficient message-passing protocol design to avoid queue delay impacting end-to-end packet delivery.

2.3 Message-Oriented Communication

Distributed control processes are inherently more scalable than centralized systems, but rely on the communication of information across processing nodes. The formulation of message passing costs, or the time required for a message to traverse the network to its destination, depends on a number of factors, to include: 1) network topology, 2) data handling and routing, and 3) protocol design. Principle parameters include [54]:

- Startup time (t_s): Message encapsulation time, route computation, radio-to-router traversal.
- Per-hop time (t_h): After a message leaves a node, the finite time required to reach the next node in the path. Specifically, interconnection switching and queuing delays.
- Per-word transfer time (t_w): Is the channel bandwidth or r words per second, expressed in terms of $t_w = \frac{1}{r}$ time, which includes link traversal and buffering.

Like the internet, MANET network designs benefit from the use of different control and data protocols. Further, protocol scalability performance varies by AS domain. Thus, the message passing use-case is significant to control and data plane designs. The three general types of message passing cost models are [54]:

- Store-and-forward routing
- Packet routing
- Cut-through routing

For non-IP type control plane protocols, which are highly influenced by link stability and mobility, efficient physical layer communication designs focus on minimally-sized control messages to avoid the overhead of routing, error correction, and sequencing information - especially since logical link control depends on high-rate low-latency communication to facilitate link closure [23]. Also, neighbor-based topology control protocols typically avoid long-haul communications to benefit from information spa-

tial locality [23]. This use-case best matches a store-and-forward communication model.

Per [54], store-and-forward is defined as message communication traversing multiple links, where each node receives the entire message before forwarding to the next node, in a linear chain. Let the size of the message be denoted as m and the number of links traversed by l , then the non-congested communication cost is:

$$t_{comm} = t_s + (mt_w + t_h)l \quad (1)$$

Alternatively a store-and-forward approach is not optimal for large and streaming data, which requires data to be transferred using multiple packets. In this case, packet routing is a much more efficient method to minimize overhead due to packet loss, forward error correction, and dynamic network conditions. Consequently, packet routing is better suited for bulk and long-haul transfers spanning multiple AS domains.

Lastly, cut-through routing is an efficient method for flow-based data routing approaches like [55]. However, cut-through routing is subject to deadlocks given route failures, and thus not well suited for control plane traffic.

2.4 Scheduling Environment Assumptions

Since different logical link rescheduling strategies handle disturbances (like link failures, processing time delays, responsiveness, information availability, resources) differently, strategy selection is a major topology control protocol design consideration. Common scheduling strategies include:

- Dynamic: Reactive schedules dependent on high-frequency/low-latency communication. Schedules formulated using node physical layer or traffic heuristics to prioritize link switching.

- Predictive-Reactive: Two-step stability improvement approaches. Compute a global optimal, then update locally as required in response to disruption event.
- Periodic: Communication conservative approaches. Often computed in the absence of lower layer information, complicated determination of the optimal re-scheduling period. Not responsive to local link disruptions.
- Event-driven: Reactive link re-scheduling due to event, like network failure or size threshold exceeded, node join/leave, way-point arrival, etc.

One of the major differences between wired and wireless communication cost models is the per-hop time (t_h) assumption, which is negligible in wired networks. Even in IP-type/contention-based wireless networks, t_h is typically dominated by t_w and, thus, ignored. For non-IP type/non-contention based airborne MANETs, where the majority of message traffic traditionally consists of smaller/hand-crafted packets as compared to IP-standard traffic, this assumption is invalid. Additionally non-contention based communication designs are subject to additional t_h latency due to channel partitioning, further increasing the parameters' expected variance range.

Due to the relatively slow and asymmetric propagation of control information across all airborne nodes, achieving a scalable per-packet topology control design is extremely problematic. Alternatively, if information used to compute a structured topology is outdated there is a greater likelihood of logical-link control errors, which may trigger costly topology recovery communication behaviors and/or re-execution of expensive topology control computation [23]. Thus, periodic logical-link schedules should be formulated on information that is relatively 'resilient' to node mobility, such as neighbor ordering, to safeguard network connectivity [23].

Also, route maintenance is inherently difficult for airborne MANET, especially with respect to scalability and mobility [19, 40]. Complicating network design and evaluation, performance and message passing cost vary considerably depending on routing technique used [54]. Also, considerable research has been dedicated to the performance and cost trade-off between securing reliability through routing vs. topol-

ogy control mechanisms [56].

Through link selection, topology control can improve both route and control plane reliability by reduction of single points of failure [57]. Benefits of k-connected topology control schemes include per-node load balancing and multiplicity of data paths, but at the cost of decreased topology flexibility and efficiency. Alternatively non-minimal adaptive (aka, on-demand) routing offer greater potential utilization and performance of channel resources, but requires a datalink layer (see Fig 13) feedback mechanism and increased information exchanges to learn current network state to successfully detect congestion and route traffic flows around it. Unfortunately, the process to discover two or more disjoint paths and maintain end-to-end coherent flows for MANETs in general, regardless of the routing approach (reactive, proactive, hybrid, hierarchical, multipath, multicast, location-aware) used, is both highly problematic and costly [58–61].

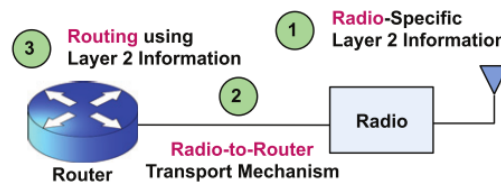

Figure 13. Radio-to-router interface by [45]

Consequently, to further increase stability and resource utilization resulting from periodic network optimization approaches, several researchers have proposed hybrid topology control methods (see Fig 25) [20, 62].

Enabling semi-dynamic link scheduling, cooperative control methods are especially promising to multi-channel communication architectures [21]. Based on feedback from real-time event detection or a lower layer heuristic (like packet-error-rate, traffic load and pattern), adaptive controllers merge network-wide infrastructure connectivity

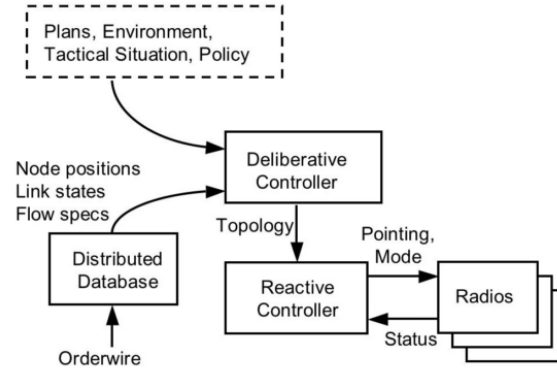

Figure 14. Deliberative/reactive controller by [20]

requirements (i.e., control plane) and opportunistic linking by combining structured and unstructured P2P link schedules [45]. Especially for bursty traffic, optimal link selection and improved multiplexing (i.e., load balancing) are advantageous towards reducing network congestion and decreasing traffic latency [56].

However, the higher frequency of link change increases bandwidth consumed by neighbor discovery and by transmit/receive nodes to facilitate beam-steering pre-coordination/synchronization. Also, depending on the wireless communication system channel partitioning approach used, additional latency penalties may be accrued due to timeslot sequencing. Unfortunately, propagating availability of a new route to deterministic routing protocols is inherently problematic, since it necessitates sustained route maintenance (in the form of additional communication) to facilitate discovery [60]. Thus, to fully exploit hybrid controller benefits, new routing protocols designed to perform well under imperfect conditions are needed [18]. Potential emerging solutions, especially well-suited for 5G aircraft (due to inherent accessibility of state-vector information for all observed tracks), include spatial (or dimensional) routing techniques which have been shown to improve packet delivery and network scalability [19, 40, 60, 63].

2.5 Multiple Access Interference (MAI)

Although this work does not specialize in types of noise, fading models, or the details of signal detection, we will review some important issues related to interference. Wireless mesh network research has shown that not just noise, but co-channel interference can significantly degrade the overall network capacity [21, 64]. Additionally, MIMO systems have been found to perform more efficiently under non-Gaussian noise conditions [64, 65]. Thus, characteristics like direction and intensity of an interference source must be taken into account for design of scalable directional networks.

Extensive research has been conducted in the area of minimizing interference at the receiver due to co-channel interference (or channel contention), which causes an increased BER at the physical layer, by implicit topology control and/or with precise power control [11]. However, efforts to implicitly minimize interference through topology control working to safeguard spatial diversity through structures, sparseness and low-nodal degree are limited [21, 66]. As a result, researchers have pursued layered approaches that combine classical topology and power control techniques with co-existence mechanisms, considerably increasing hardware and medium access control (MAC) protocol complexity, to overcome open-air communication challenges [27, 67, 68].

Several interference protocol models have been invalidated due to a lack of effects aggregation [21]. Much of the existing topology control literature focuses on either spatial or temporal impacts. Our formulation of directional MANET connectivity and topology control accounts for both domains, since either type of conflict can corrupt data packets reducing network capacity. The mathematical representation for channel capacity, if the channel is subject to additive noise with a constant power spectral density and with a Gaussian amplitude distribution, is Shannon's Theorem (below). This formula yields an upper bound to the capacity of a link, in bits per

second (bps), as a function of the available bandwidth and the signal-to-noise (SNR) ratio of the link. We observe that effective power control can have a positive effect on reducing the number of neighbors contending for channel access.

$$\text{capacity} = \text{bandwidth} \times \log_2 \left(1 + \frac{S}{N} \right) \quad (2)$$

One of the most common uses of feedback on point-to-point channels is to acknowledge when packets are received correctly (ACK) and to send retransmission requests (ARQ) when data is corrupted. Not only does the increased BER effectively reduce the actual bandwidth of the receiver, but it also causes an increase in the number of packet retransmissions, reducing available capacity. The expected contention of a receiver with omni-directional antennas assuming a random, uniform node distribution can be expressed as:

$$E(k_{\text{neighbors}}) = \frac{\pi r^2 (n - 1)}{A} \quad (3)$$

From the above equations, we observe that wireless network interference is a function of both MAC protocol effectiveness and physical interference. Thus, interference is frequently modeled in terms of protocol and physical interference. We briefly describe the differences between the two fundamental models below, which form the building blocks to specialized directional and multi-channel interference models which include additional factors for antenna pointing, polarization, co-link interference and noise, synchronization error, atmospheric absorption, etc. [21, 23]:

- Protocol Interference Model: Let X_i denote the node identity and location. Node X_i transmits over the directional channel to a node X_j . Then this trans-

mission is successfully received by X_j if the intended destination of X_j is outside the coverage area of any other simultaneous transmissions over the same channel, such that:

$$|X_k - X_j| \geq (1 + \Delta)|X_i - X_j| \quad (4)$$

In the formation above, the constant $\Delta > 0$ specifies a guard zone to avoid neighboring nodes from transmitting on the same channel at the same time. An advantage of this basic model, is that it easily maps to a graph-coloring schedule problem, where the computed schedule corresponds to the orthogonal mechanism (i.e., a time-slot, frequency or code assignment) used by a non-contention based MAC protocol.

- Physical Interference Model: Modeled in terms of received power, free-space propagation (eq 5) is frequently used to compute signal propagation under idealized conditions for an single-channel omni-direction transmission with a clear line-of-sight to the receiver. The received signal power is denoted as $P_r(d)$ for a given distance d to the transmitter.

$$P_r(d) = \frac{P_t G_t G_r \lambda^2}{(4\pi)^2 d^2 L} \quad (5)$$

where

P_t = Transmit power

G_t = Antenna gain at transmitter

G_r = Antenna gain at receiver

λ = Wavelength

L = System loss (not due to propagation)

In [69], the authors detail how (eq 5) can be extended to directional antennas, since the received signal power at the receiver depends on the relative locations and the antennas' pointing directions, by grouping the possible transmitter/receiver associations into four different categories (or modes) defined in Fig 16.

The antenna pattern is modeled (see Fig 15) by a circular sector main beam,

where the a beamwidth is defined by $\Delta\theta$, and a circular side lobe outside the main lobe sector. Each node is assumed to use the main beam of a directional antenna for both transmission and receiving, i.e., the main beams are aligned for both transmitter and receiver antennas.

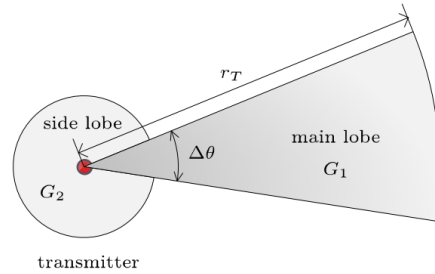

Figure 15. Direction antenna pattern model by [69]

Also, the model assumes that the directional antennas on each node are identical.

mode	transmitter	receiver
11	mainlobe	mainlobe
12	mainlobe	sidelobe
21	sidelobe	mainlobe
22	sidelobe	sidelobe

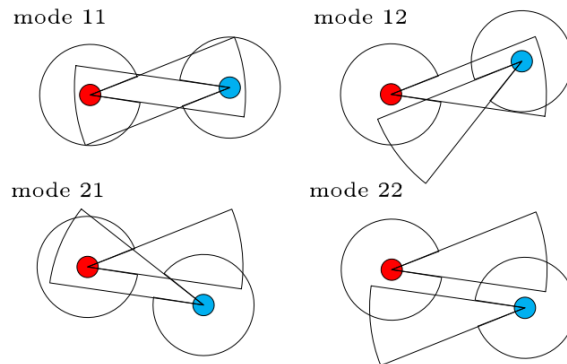

Figure 16. Directional antenna link modes by [69]

The new formulation of (eq 6) where the values for i and j are the mode of the link is:

$$P_{ij}(d) = \frac{P_t G_i G_j \lambda^2}{(4\pi)^2 d^2 L} \quad (6)$$

for

$$i, j = 1, 2$$

The next step towards calculating directional network capacity is formulating signal-to-interference-plus-noise (SINR). The SINR equation extends the physical interference model defined in eq 6 to include co-channel interference, since other nodes may be operating simultaneously on the same channel within the receiver interference susceptibility coverage area [69]. The SINR at receiver u is defined as:

$$\text{SINR} = \frac{\phi_u^{(s)}}{N_0 + \phi_U^{(I)}} = \frac{\phi_u^{(s)}}{N_0 + \sum_{i \in \Theta_I} \phi_U^{(I)}} \quad (7)$$

where

$\{s, u\}$ = The transmitter/receiver node pair

Θ_I = All co-channel interference nodes for node pair $\{s, u\}$

s_i = Interference causing transmission (given mode) at u

N_0 = Mean receiver noise power at u

$\phi_u^{(s)}$ = Signal strength (power) from s

The physical interference model now includes both transmission/receive geometries and co-channel effects. Substituting it into (eq 2) for SNR yields the single-hop capacity denoted C_{SH} :

$$C_{SH} = \text{bandwidth} \times \log_2 \left(1 + \frac{\phi_u^{(s)}}{N_0 + \sum_{i \in \Theta_I} \phi_U^{(I)}} \right) \quad (8)$$

Finding the multi-hop transmission capacity (eq 9 below) is found by solving for the minimum capacity P2P link between any two end-points. Let n denote the total number of P2P links, where $l_n = \{s_1 u_1, \dots, s_n u_n\}$ relates to a node pair. Thus, $l_1 \dots l_n$ denotes the set of links required by a flow between any two given end-points.

$$C_{MH} = \frac{1}{n} \min_{l_1 \dots l_n} \{C_{SH}\} \quad (9)$$

2.6 Directional Antenna Design Challenges

To avoid the computational difficulties of modeling cumulative interference, the vast majority of available topology control research assumes only pairwise interference. In this section, we provide some examples to demonstrate why this is an unrealistic assumption for D-MANET.

As discussed above, directional antennas provide increased communication flexibility and capacity advantageous through spatial diversity. However their introduction in wireless network introduces several design challenges, especially related to channel sensing. The three types of two-neighbor communication scenarios are:

- Omni-Omni: Both neighbors are within omni-directional range for neighbor discovery, channel sense and receive communication.
- Omni-Directional: Only one neighbor is within omni-directional range for neighbor discovery, channel sense and receive communication.
- Directional-Directional: Both neighbors are outside omni-directional range. Neighbor discovery, channel sense and receive coordination completed with directional-mode.

Figure 17 illustrates classical co-channel interference as the result of two neighboring nodes transmitting to each other at the same time. This interference can be mitigated through use of medium access protocols, like time-division multiple access (TDMA), which will be described in greater detail in Sect 2.7. Unfortunately, to safeguard channel access protocol efficiency, most message exchange schemes or handshake mechanisms do not guarantee interference avoidance for neighboring nodes more than one-hop away, thus, even for sparse networks such interference can't be fully mitigated [21]. Moreover, for MANETs with non-uniform node distributions like tactical airborne networks, there is an even greater likelihood of harmful co-channel interference reducing network capacity and scalability. Additionally non-uniform interference causes asymmetrical link-rates, which contributes to formation of bottle necks within the multi-hop network topology.

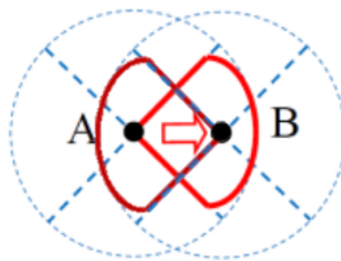

Figure 17. Contention example

The following scenarios (Fig 18) illustrate how directional antennas increase the

medium access control (MAC) protocol design burden in greater detail. For simplicity, we'll discuss the scenarios in terms of nodes with single-input single-output (SISO) channel capabilities.

Figure 18a illustrates a MAC layer capture problem in direction networks resulting from a communication intent failure discrepancy between directional-directional neighboring nodes. This figure illustrates how a receiver can use beam-forming to focus its main-lobe energy increasing directional gain towards the intended target transmitter, but at the cost of causing partial deafness in all remaining directions. In this example, node C transmission will not be detected by node A due to its relatively low gain in node C's direction.

Figure 18b depicts a hidden terminal problem, where one or more neighboring nodes is outside the coverage area of the transmitting node, but within the coverage area of the receiving node. In this example, nodes A and C are omni-omni neighbors using direction channel sensing. However, node C is communicating with D using a directional link, thus, node A effectively becomes a hidden terminal. Since node C directional transmission is not detected, node A transmission creates a collision at node D interfering with node C on-going transmission.

Figures 18c and 18d depict the exposed terminal problem, which is defined as a terminal within the coverage area of a transmitting node but outside the coverage area of the receiving node. In figure 18c, node A's transmission to node B is causing channel contention at node C. This example illustrates the importance of a MAC layer power control mechanism with communication system design to help mitigate undesired co-channel interference. In figure 18d, node D's transmission to node C potentially causes harmful side-lobe interference to node C. Again, we observe that a power control MAC layer mechanism will not be effective. An alternate MAC layer mechanism is needed to effectively eliminate the co-channel interference, like a

non-contention TDMA channel access protocol.

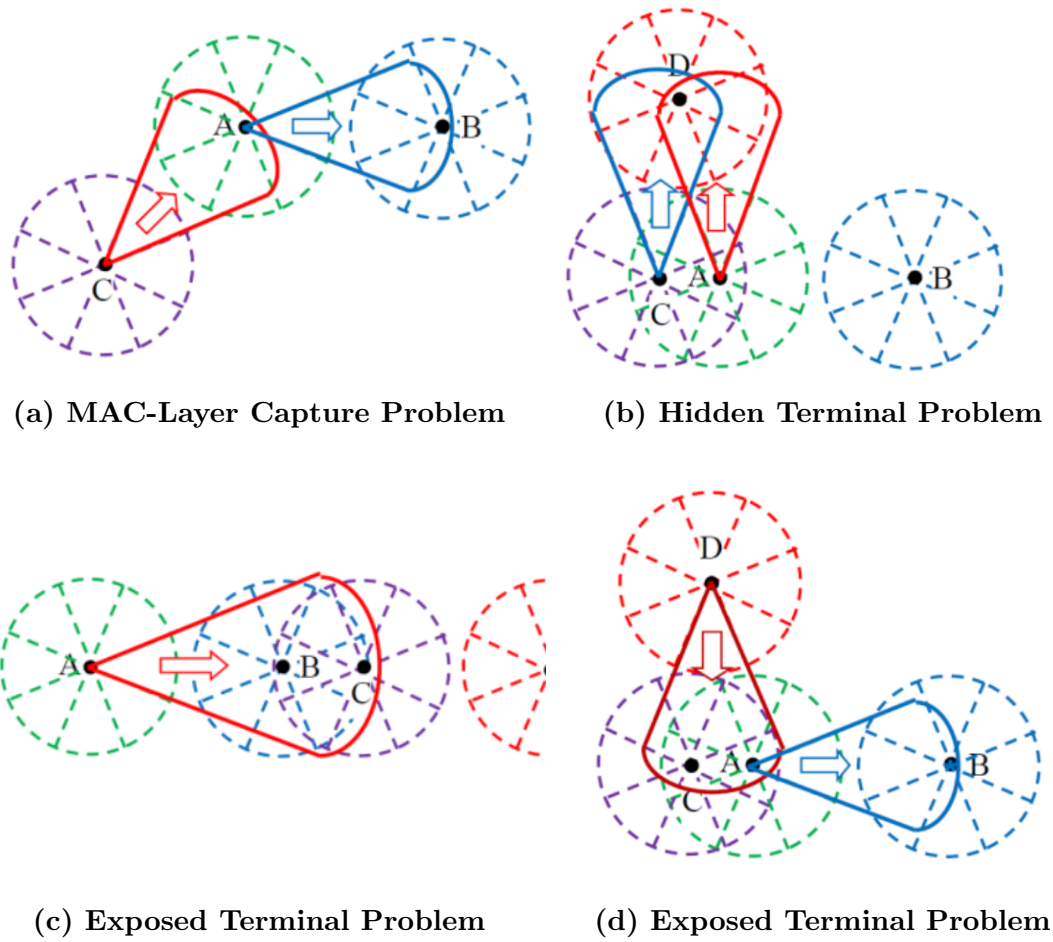

Figure 18. Directional antenna design challenge examples by [67]

This section described the different communication scenarios for directional antenna architectures. Also, it provided a brief summary of interference awareness and detection problems that must be mitigated to achieve high-capacity and scalable networks. Lastly, with respect to distributed MANET designs, it reinforced the concept introduced in Sect 2.5 that multiple techniques are required to fully mitigate co-channel interference efficiently.

2.7 Medium Access Control (MAC)

Enabling interference-free spatial reuse of the electro-magnetic domain is an ongoing and active research topic in the wireless networking communities. For uniformly distributed sparse networks, increased spatial reuse benefits include greater network capacity. However, even for nodes communicating in parallel geometries, when there exist multiple nodes in close proximity, antenna side and back lobe can assert themselves causing multiple access interference. Many MAC layer techniques exist, to include newer variations and emerging hybrid techniques especially tailored for MIMO, to mitigate the undesired electro-magnetic interference suitable [21, 67, 70, 71]. Medium access approaches can be organized into three categories, which are [50]:

- Channel Partitioning Protocols
- Random Access Protocols
- Taking-Turns Protocols

The four most widely used single-channel MAC methods in wireless communication systems are: 1) time division multiple access (TDMA), 2) frequency division multiple access (FDMA), 3) code division multiple access (CDMA), and 4) carrier sense multiple access (CSMA). Each method discussed has their own strength and weakness, despite having the same spectral efficiency. For the case of CDMA it is orthogonal code, the TDMA case is timing, and for FDMA there is the difficulty of acquiring multiple spectrum allocations [72]. Further, with spread-spectrum FDMA implementations there is increased digital signal processing and filter performance cost. For CSMA, there is the issue of directional antenna sensing and fair channel access resulting in flow starvation.

Relating these methods back to the overarching NFL theorem for control described in Section 1.1, the suitability of any particular method depends on the underlying network architecture assumptions, and all methods come with their own unique chal-

lenges [9]. CDMA is well suited for MANET applications with many transceivers each generating a relatively small amount of traffic at irregular intervals. FDMA is not sub-optimal in high-mobility applications. TDMA is inefficient for applications requiring many independent time slots. For CSMA, directional antennas preclude sensing channel availability in all directions complicating collision avoidance. For dynamic packet-based implementations, the method cost is in terms of additional overhead to continually allocate and deallocate the orthogonal code, time slot or frequency channel.

When we consider that the “combat cloud” network design must be: 1) reliable - even when aircraft are within close proximity of each other, and 2) include fifth generation aircraft with integrated multi-sensor and shared data strategies that produce high data-rate and persistent traffic loads - a pure CDMA access method is not efficient. However TDMA safeguards these design goals, but requires the assumption stringent timing to support synchronous message exchanges and a sequencing cost in terms of a reduction in channel capacity equal to the number of orthogonal time divisions.

2.7.1 Time-Division Partitioning

Orthogonal channel allocations eliminate collisions and interference to provide a conflict-free medium access using time-division multiplexing (TDM). TDM allows each signal to occupy the entire bandwidth of the channel, but only for a predetermined interval of time called a timeslot. Thus, multiple signals take turns transmitting over the single channel (see Fig 19). The figure illustrates each of the four signals forming a frame being transmitted over a single channel for an interval of time, one after another. If the time slot interval and signal allocations are identical, then the frame satisfies the fair channel schedule property. The frame transmit cycle repeats

after all four independent signals have completed their allocated timeslot transmission.

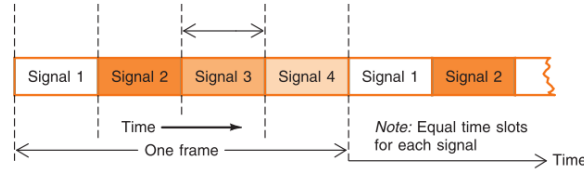

Figure 19. Time-division multiplexing by [72]

In this paper, we consider the non-trivial challenges related to migrating a static linear (i.e., pre-assigned logical links/timeslots) network topology to dynamic deterministically computed topology. Channel partitioning for multi-channel/multi-hop topologies requires explicit communication to de-conflict and synchronize multiple potential senders and receivers to avoid harmful interference and assures link acquisition and closure. Successful channel partitioning requires that all nodes are either pre-synchronized or execute a bootstrap routine at start-up. Once all nodes are synchronized, each node has the knowledge of which node is the sender of each message. However, in the case of a transient fault causing a node to timeslot synchronization, a node may fail to be heard (due to the MAC-layer capture problem) and/or cause harmful interference to nearby neighbors extending the nodes entry back into the network [21].

Although channel partitioning is less flexible than other media access methods, the deterministic behavior is advantageous to estimation of packet arrival times and worst case delays, since the establishment of an latency upper-bound highly influences protocol design and performance. However, schedule efficiency (i.e., minimizing the number of channel partitions) is crucial to latency interconnection performance in forwarding multi-hop topologies [73].

For small network size, node transmit/receive synchronization can be easily accom-

plished through fixed or token-based scheduling methods [74]. Unfortunately, these deterministic types of coordination mechanisms lack the desired scalable and mobility independent design properties needed to minimize node starvation and mitigate co-channel interference. Semi-dynamic scheduling approaches utilize fixed mechanisms initially, then organize nodes into different partitions to preserve spatial diversity [21]. Partition re-assignment is then accomplished via distributed control, which requires detailed coordination in terms of hand-shaking messages between senders and receivers [73].

Algorithms

Graph-based coloring algorithms are an active and widely studied topic in communication and discrete mathematics communities, since finding an optimal graph coloring closely relates to an optimal node partition assignment schedule. Per the four color theorem no more than four chromatic colors are needed to delineate all regions sharing a common boundary (other than a single point), which is essential to establishment of an channel efficiency upper bound [75]. Exact algorithms can be formulated in terms of a maximum clique problem. Unfortunately, finding the minimum number (worst-case) of colorings is computationally expensive (NP-hard) - see [76] for a detailed proof. Consequently, many embedded real-time systems must leverage approximation and heuristic algorithms [77–79]. Some well-known combinatorial techniques used in the literature include:

- Sequential coloring: Vertices are ordered in the sequence to be colored. The order remains constant during algorithm execution. Given an optimal ordering (NP-complete), the algorithm will always find an optimal coloring. This technique is frequently applied to graph re-coloring problems, since vertices can be ordered by current color assignment minimizing re-colorings in successor solutions.
- DSATUR: Similar to the sequential algorithm except that the node ordering is

dynamically determined after each node has been colored to minimize conflicts with previously colored vertices (also known as maximum degree of saturation selection process) [80, 81]. Vertices are initially ordered by degree (either by increasing or decreasing depending on the algorithm).

Per [76, 77, 81] combined techniques offer greatest performance in most cases.

Some methods include:

- Iterative Greedy: Given an initial coloring of the vertices, then searches for a new coloring using no more colors than the previous coloring. The local search method works by exchanging each color class prior to calling the primary coloring algorithm (greedy, sequential, etc) - a technique known as exchange neighborhoods [76]. Iterations continue until an upper limit is reached, then the best solution thus far is selected.
- Brute force: Recursively enumerate all candidate solutions by depth-first branch-and-bound exhaustive search with cutting plane methods [76, 80].
- Backtracking: A depth-first search method, which terminates upon finding the first solution [54]. This method is advantageous to computation speedup since it avoids re-computation from scratch, however, it is not guaranteed to find a minimum-cost solution. The challenge with backtracking is determining back-track distance from graph coloring threshold (upper-bound).
- TABU search: Is a metaheuristic algorithm, frequently extends a greedy partial solution. Works to overcome local optimality by accepting non-improving solutions as well as improving ones, by making a reversal move for a certain number of iterations. Continues for a given number of iterations, or if no improvement has been found after a certain number of steps of successive iterations [82].

Impact of partitioning on multi-hop forwarding

To illustrate the multi-hop forwarding latency effect resulting from a semi-dynamic slotted time division multiple access scheme, we calculate the upper and lower time to communicate bounds (see Fig 20) using the store and forward model from Sect 2.3 (eq 1) for the notional parameters listed in table 2. Recall that the per-hop time

random variable (t_h) corresponds to the interconnection switching and queuing time delay, which includes channel partition sequence mismatch. Also, that the startup time (t_s) random variable includes message encapsulation time, route computation, radio-to-router traversal. Lastly, the per-word transfer time (t_w) random variable includes link traversal and buffering.

Table 2. Time to communicate (T_{comm}) parameters

Property	Value
Timeslots	4 partitions
t_s	25 ms
t_h	25-75 ms
t_w	240 μs

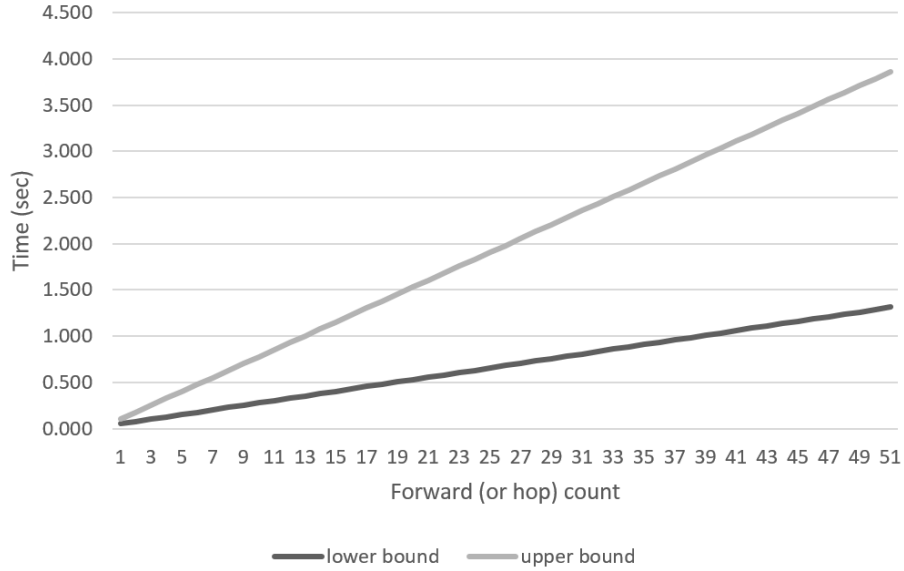

Figure 20. Timeslot sequencing example

From Fig 20, we remark that a semi-dynamic slotted time division multiple access scheme are subject to greater potential latency variability (due to the non-sequential

partition assignments) as the path length increases. Again, another example of “No free lunch” (NFL) theorem of complexity, since a careful balance is needed between optimal colorings (for resource efficiency and latency performance) and costly communication avoidance (resulting from local and neighborhood exchange synchronization). With respect topology control protocols, scalable designs must account for increased latency variability and adapt with network size.

2.7.2 Directional Medium Access Control (DMAC) Protocols

Improving instantaneous throughput through channel aggregation (see Fig 4), traditional multi-channel channel assignment methods can be organized into three main types, which are [21]:

- Fixed
- Semi-dynamic
- Dynamic

For small tactical networks, simplistic assignment methods can effectively provide a conflict-free medium absent of any synchronization cost [53]. Unfortunately the underlying linear topology and routing scheme are also fixed, which causes scalability issues like increased network partition susceptibility and decreased link stability [21]. Thus, static methods are not suitable for distributed operation scenarios comprised of chaotic groups of autonomous systems.

In semi-dynamic methods, channel assignments are updated over time to minimize harmful interference using graph-based techniques [21]. However, pre-coordination communication and time synchronization is needed to facilitate channel assignment changes. Semi-dynamic methods reduce partition occurrence, which improves link reliability and throughput. To mitigate directional channel switching problems (like hidden terminals, channel capture, and exposed terminal problems) sender and receiver must exchange spatial (i.e., terrestrial coordinates) information via a dedicated

control channel. Further, some semi-dynamic methods leverage cross-layer techniques, which combine routing, channel assignment, and topology control protocols, for additional performance gains [67, 79].

The third category of dynamic methods includes cross-layer approaches that integrate channel measurement and dedicated coordination frames prior to each data packet transmission [21, 67]. Exchanging separate control and data frames further improves contention avoidance and eliminates the need for multi-hop synchronization communication. However, protocol performance is increasingly contingent upon the underlying beam-steering and switching time, since additional sense cycles are needed to synchronize and schedule channel access in a circular sequence (see Fig 21)[21, 67].

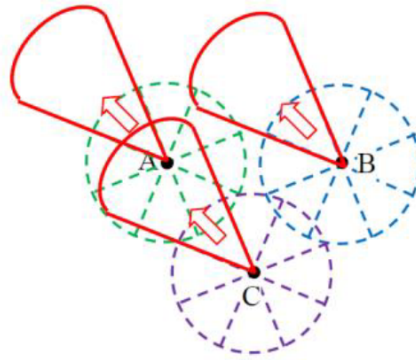

Figure 21. Contention-based circular DMAC protocol visualization by [67]

To maximize spatial reuse efficiency gains, the most recent research focuses on cooperative protocols (see Fig 22) designed exclusively for modern smart antennas. This class of directional multi-channel protocols can be divided into two categories [67]:

- Contention-based
- Hybrid-based

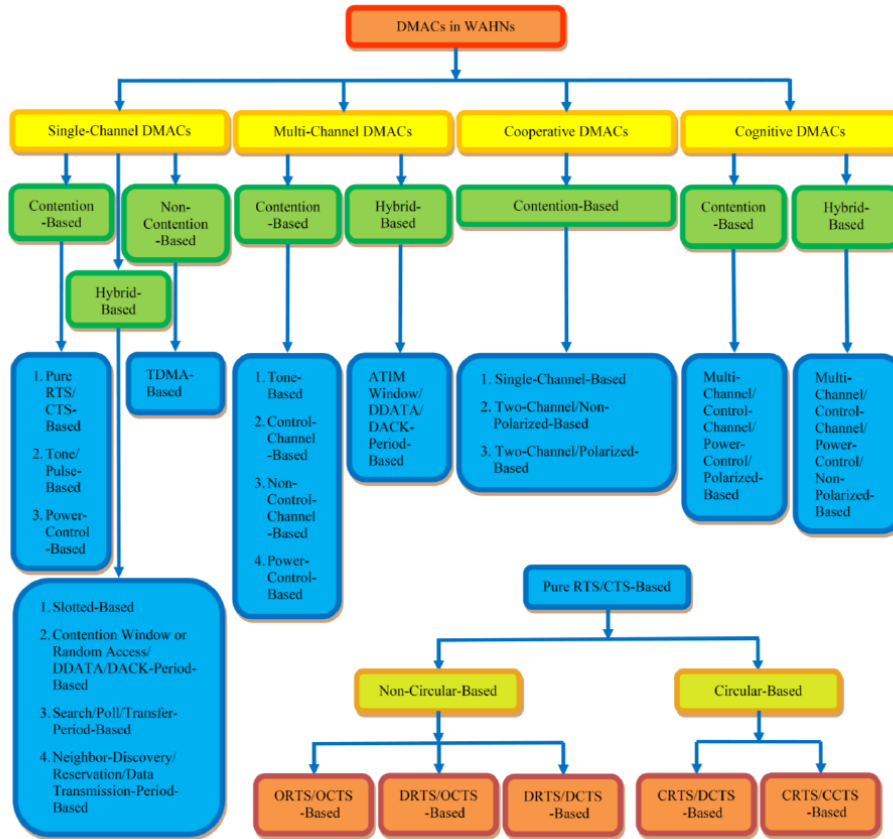

Figure 22. DMAC protocols taxonomy by [67]

Contention-based protocols are tightly coupled with the underlying communication system architecture and are fundamentally different from traditional TDMA-based protocols. Due to the directional antenna asymmetric gain, coordination transmissions, like ready-to-send (RTS) and clear-to-send (CTS), must be transmitted in circular patterns [64, 67]. Since node overlaps can be easily detected, hidden and exposed terminal problems can be reduced. Unexpected synchronization frames received by neighboring nodes provide direction-of-arrival and timing information, which facilitate signal nulling and avoidance of harmful interference. Unfortunately, recall that strict QoS schemes cannot be guaranteed for contention based approaches [64]. Despite the spatial re-use gains of directional antennas contention based approaches suffer under dense, like that of tightly coupled aircraft formations, and heavily loaded

network conditions [83].

Hybrid-based multi-channel techniques are encouraging, since this sub-class partially overcomes traditional single-channel scheduling efficiency limitations by combining contention and non-contention based methods. Similar to the contention-based protocols, all nodes are forced to listen during a contention time period at pre-defined data rate followed by a non-contention time period for data transmission at a negotiated higher data rate [67]. To facilitate increased aggregate throughput, some techniques incorporate both power and antenna pattern information (see Fig 23) into control frames [68]. Also, this protocol class decreases timeslot sequencing latency (see Fig 20) in many scenarios, due to fewer overall channel partitions over time (known as TDMA slot re-use in some literature). Further, the added timeslot allocation flexibility decreases the channel synchronization to data overhead ratio (see Fig 24).

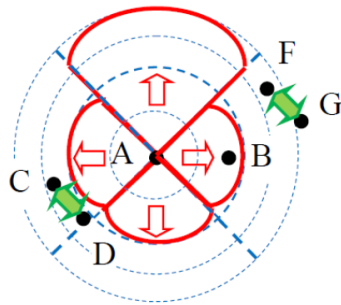

Figure 23. Interference avoidance with power control by [67]

2.8 Neighbor Discovery

Timely discovery of all neighboring nodes and their antenna beam directions has a great impact on the directional MANET protocol design, in addition to signal

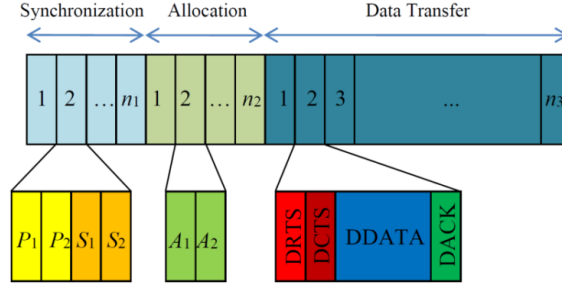

Figure 24. Hybrid-based single-channel DMAC protocol by [67]

LPD/LPI design performance [67]. There are two main types of neighbor discovery approaches, which are [26]:

- Blind
- Informed

Blind techniques periodically sweep the search space actively working to establish new links up to the maximum range of the direction antennas. Upon establishing a link, a discovery announcement packet (or “Hello” message) is broadcast to connected neighbors. Although proactive search space discovery results in faster bridging of network partitions, there is a trade-off between neighbor discovery efficiency and LPD/LPI properties [26]. Consequently, in this work we pursue topology control structures (i.e., k -connected topologies) which minimize the need for active sweeping searches.

Informed neighbor discovery processes establish links through shared position and timing data derived from an aircraft system, for example, an inertial navigation system or global position system [26]. In addition to the acceptance of local navigation and timing information dependencies, this approach depends on establishing links through pre-coordination up to the maximum transmission distance. Per Sect 2.6, the directional transmitter and receiver must both synchronize their beam-steering and channel actions to achieve an optimal gain to maximize the probability of successful link acquisition. Further, if dissimilar communication architectures are used,

information exchanges must also include the number of available channels and antenna type [68].

Recall from Sect 2.2 that current airborne intra-flight datalink capability are predicated on linear-topology/time-division channel access methods. Transition to dynamic-topology/channel access methods results in new neighbor discovery coordination challenges, since information may traverse dynamically across multiple routes. Unfortunately, robust and timely neighbor discovery algorithms for multi-channel DMAC are still in the early stages, especially for real-time applications [67]. Another non-trivial challenge for multi-hop (or relay) networks is how to bound positional errors, since asymmetric latency is accrued with each hop (Fig 20). In figure 25, the different types of coordination scenarios are depicted. Assuming perfect channel conditions, current intra-flight neighbor coordination schemes are likely to resemble the timings depicted by Fig 25a. Given non-perfect channel conditions, the coordination would resemble Fig 25b. For multi-hop forwarded coordination, Fig 25c/d depicts the effect of latency growth on the neighbor discovery process.

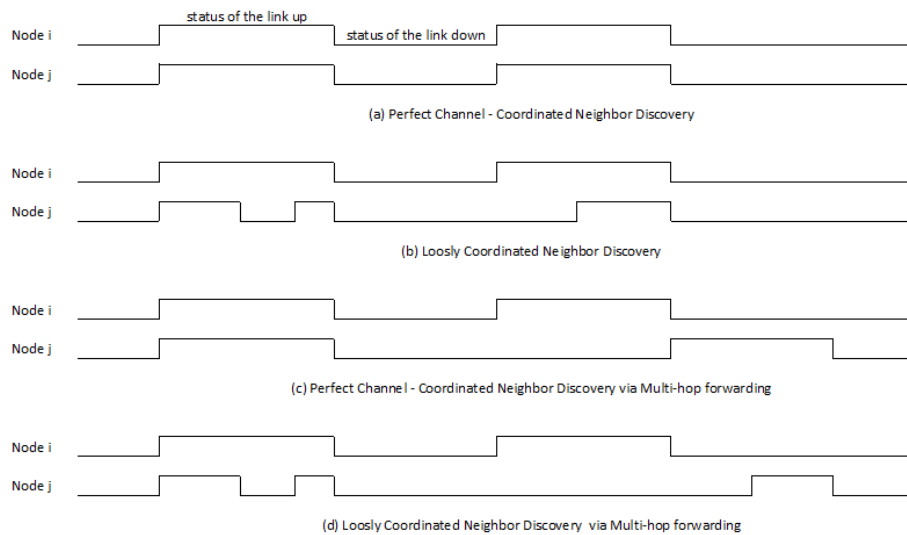

Figure 25. Neighbor discovery coordination inspired by [84]

Another challenge to informed protocol development is related to how a neighborhood is defined, which dictates how and at what frequency interval neighbor discovery announcement messages must be forwarded. Traditional protocols frequently define neighborhoods by the set of nodes meeting a hop count limit. Alternatively, the directional MANET protocol trend is to define the neighborhood by the greatest achievable distance possible [68]. Since neighbor discovery traffic consumes finite control plane bandwidth, more efficient protocols that can adapt to channel conditions, network topology and size, and node mobility changes are needed [67]. In addition, some researchers have found that is not enough to just purge stale neighbor discovery entries for highly-dynamic airborne environments, but rather predict neighbors that will be out of range [40]. Thus, as described in Sect 2.4, leveraging cooperative avionics information exchanges could be advantageous to future cognitive protocol development.

2.9 Topology Reconfiguration

There are still many technology challenges related to implementation and demonstration towards fielding a stable autonomously controlled high-capacity airborne network [17]. To further narrow our research goals, this paper focuses on investigation of methods suitable for military tactical airborne networks, which are: structureless, extremely mobile, and have relatively low-bandwidth [7] as compared to other MANETs. Additionally, tactical P2P networks must support a diverse suite of applications that benefit from different performance attributes (or tuning). Further, tactical airborne networks must be scalable up to 50 nodes in order to achieve distributed Command, Control, Communications, Computers, Intelligence, Surveillance and Reconnaissance (C4ISR) operational gains [1]. Further complicating information sharing, recent sensor technology advances make available massive amounts of data

supporting a detailed analysis of enemy forces and capabilities. Thus, the network designers' #1 challenge has become how to best use limited resources in flexible ways.

2.9.1 Optimization and Performance

Physical topology design can be a significant performance factor in systems that require high-consistency, which is often achieved at the expense of availability [85]. Moreover, the finite bandwidth constraint of P2P tactical airborne networks necessitates the need for very efficient topology control techniques. This places increased importance on the need to quantify end-to-end application performance, in addition to traditional topology metrics. Some factors include:

Impacts at upper levels

Asynchronous target topology deployment increases the potential for network congestion and channel contention, which can cause network instability, race conditions, and reduced network capacity [86].

Real-time constraints

Target topologies must be efficiently computed to support both mobility and PAT. Simultaneity assumptions can introduce significant error even during moderate motion. Failed target topology deployment increases the potential for network partitions and hidden terminals decreasing network capacity.

Data consistency and availability

Fifth generation tactical aircraft (defined by their low-observable, enhanced situational awareness, agility, speed and precision attack capabilities) benefit from integrated multi-sensor and shared data strategies [24]. To facilitate data analysis pro-

cesses, the underlying P2P networks must provide predictable levels of performance (consistency, latency, availability) to network applications and some instances, new proprietary protocols have been required [7, 9, 19].

2.9.2 Protocols and Design Considerations

Topology control protocols differ by technology and architecture assumptions (see Fig 26). In general, protocols can be divided into three categories, which are: 1) location, 2) direction, and 3) neighbor-based [23]. Selection of a methodology requires careful consideration, since resources (in terms of hardware and messages exchanges) vary greatly by protocol.

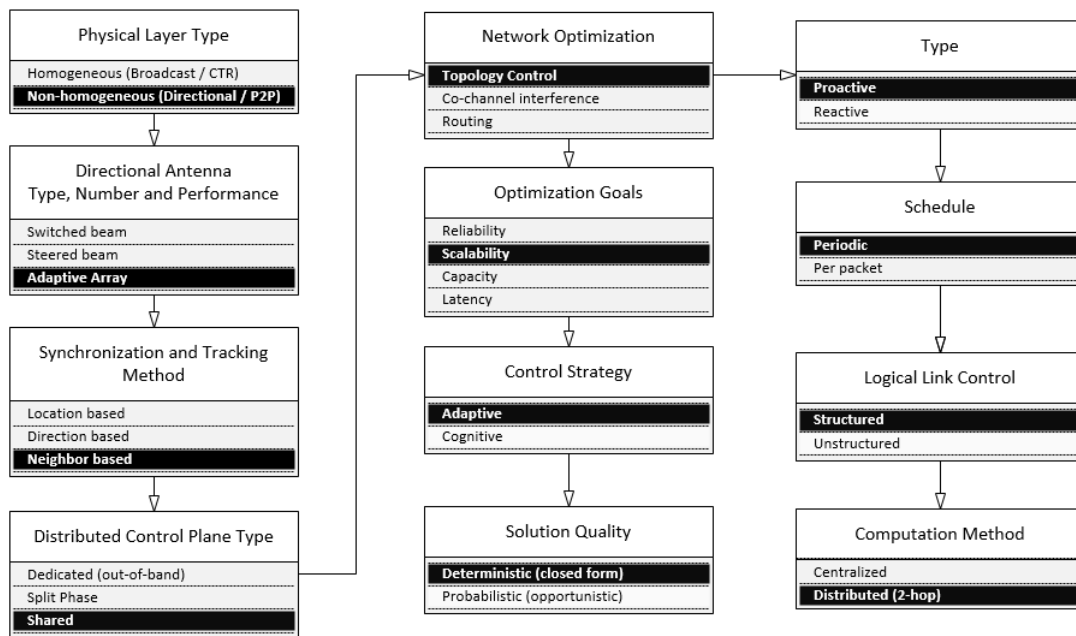

Figure 26. Protocol design decomposition example

Some researchers have focused on alternatives to new protocol development, like software defined networking. A strength of software defined networking is that standardized interface provides topology control with the needed mechanisms to quickly

adapt to changing network performance requirements [87]. For example, providing link layer feedback to a router significantly improves multi-hop computation accuracy [17]. A high-speed switching fabric interface enables more efficient, comprehensive (see Fig 27) and proactive topology control solutions [88].

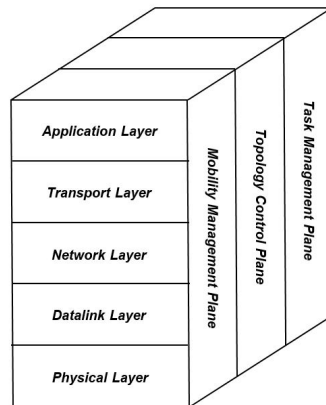

Figure 27. Network stack with cross-layer control planes

2.9.3 Algorithms

Topology control algorithms and methods have been extensively studied for decades, however, physical deployment of self-organizing network capabilities is still in the early stages. Contributing to the slow roll-out of capability include technical complexity and performance challenges that are difficult to model, simulate and flight test [9, 17, 45].

A priority and on-going research challenge in the design of a directional wireless high-mobility network is to assure robust network performance in a highly dynamic wireless environment [56]. There are two main approaches to recover from faults, which include reactive (accomplished through node repositioning) and provisioned responses. The simplistic provisioned response is to impose bi-connectivity constraints on the network, which safeguards against a single node failure. However, this results in

multi-hop topologies that increase routing demands and end-to-end latency. For even greater scalability and reliability, k-connected topologies provide k-fault tolerance [57].

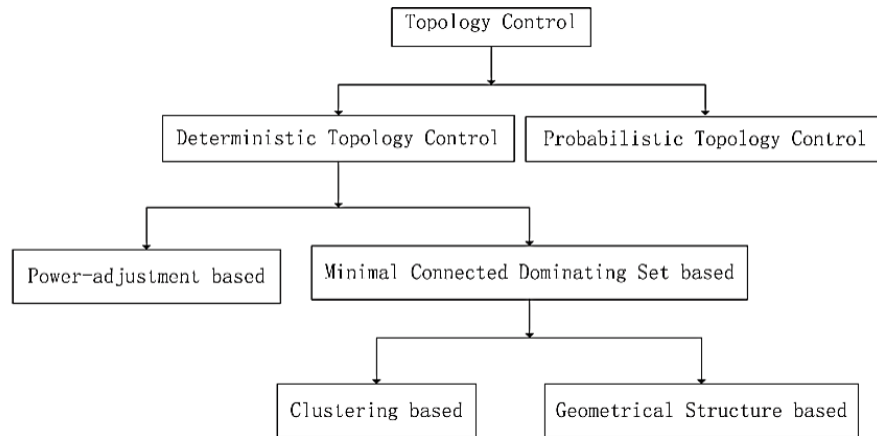

Figure 28. Topology control taxonomy by [18]

Even for ring topologies, which assume a shortest path routing, the topology computation problem is NP-complete. However, many heuristic selection approaches are available [22, 89]. The type and number of heuristics used must be carefully considered to minimize resource impacts (communication, computation). For example, roll-out heuristics evaluate complete topologies at every step to compute reconfiguration cost, but require increased resources to do so [22]. Additionally, many alternative methods have been proposed and studied. Some involve simultaneous topology computation to support branch-exchange or implement informed search methods to yield successive morphing to target topology [20, 89–91]. Other methods leverage predictable group mobility and network structures to support adaptive clustering [92–94].

Since a fully distributed, asynchronous and neighbor-based methodology best matches the tactical P2P airborne domain constraints and performance goals, we will again narrow our focus to scalable k-connected computational approaches. One such computationally conservative approach is the Dominating Set Based Algorithm

(DSBA), which first builds a dominating set from a graph. Subsequently, using a two-step ring based connection strategy (see Fig 29), it adds edges to satisfy the k -connectivity constraint [95]. One of the main features of the algorithm is that it builds m -dominating sets first and adds edges to achieve k -connect dominating sets. This is advantageous to graphs with non-uniform distributions like tactical airborne networks, which organize into strike packages. The streamlined connectivity minimizes routing latency while the k -connectivity supports increased reliability between strike packages. Per [95] analysis, DBSA showed a 30% performance improvement over Distributed Deterministically Algorithm (DDA) in practical simulations.

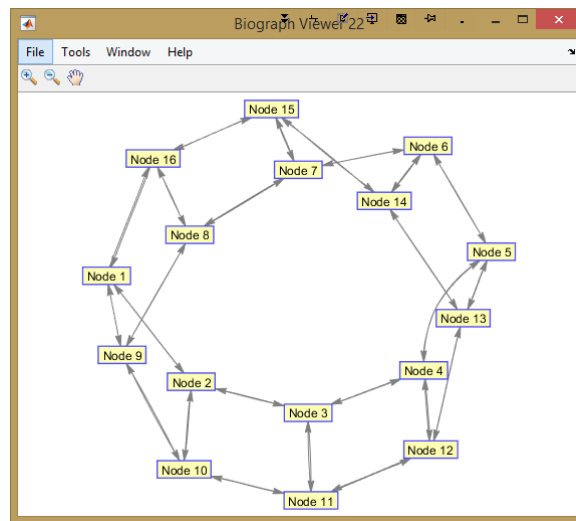

Figure 29. 3-way k -connected topology example

III. Experiments and Results

This chapter captures our first and second screening design in an iterative process designed to focus model fidelity on features of significant impact to autonomous topology control protocol development and evaluation.

Warfighter takeaways:

- *Network scalability and communication quality is contingent upon early antenna design choices*
- *Reliable and scalable “combat cloud” architectures will require additional channel resources*
- *Incremental network capability development approaches will likely be less efficient and exhibit greater overall life-cycle cost*
- *Programs must carefully consider the efficiency impact of backwards compatibility*
- *The absence of performance thresholds, especially for the lower-layers, will delay interoperable capability fielding*
- *Multi-hop timeslot sequencing potentially problematic for time-sensitive 5G aircraft processes*

3.1 Topology Control Experiment

Using simulation we derived multiple classical performance metrics to evaluate topology reconfiguration effectiveness. Further, we used four different sets of P2P network construction attributes to study the relationship between the underlying

topology design elements and the resulting effect on scalability and partition avoidance.

The following describes the autonomous topology control experimental goals, setup and controls.

3.1.1 Experiment Purpose and Goals

One contribution of this thesis is to explore military relevant P2P network architectures for the purpose of qualifying factors that statistically impact autonomous topology control performance and to offer insight into several practical acquisition community questions, like:

- What are the common services and design requirements needed to field self-forming, self-managing directional tactical datalink networks?
- What are implementation risks of autonomous topology control capabilities?
- What is the cost (in terms of bandwidth) of autonomous topology control?
- Can current intra-flight datalink investments be augmented to support distributed operations? If so, what additional resources or upgrades are required?

3.1.2 Design of Experiments (DoE)

We utilize a design-of-experiments process and methodology to support deriving statistical relevant experimental outcomes. This section presents results from a screening design conducted to support a reduction of statistically non-relevant factors and to guide future model fidelity improvement priorities.

Table 3. Factor dimensions, complexity and levels

Factor	Treatment	Units
topology algorithm	k-connected m-set	
optimization method	deterministic	
optimization interval	10, 30, 60	s
physical search space size	150	nm
degree distribution	3-6	edges
critical tx range (CTR)	50, 100, 150	nm
number of nodes	8, 18, 24, 48	vertices

The following table summarizes the fractional factorial design:

Table 4. ATC experiment configurations

Parameter	Block 1	Block 2	Block 3	Block 4
duration	360 s	360 s	360 s	360 s
nodes	24	18	8	48
k-deg (max)	4	5	6	3
CTR	50 nm	100 nm	150 nm	50 nm
ATC reconfig	10 s	30 s	60 s	60 s

3.1.3 Network Dynamics

Mobility model selection and configuration play a significant role in realistic topology control simulation [96]. The following table summarizes parameters used in this experiment.

Table 5. Random waypoint mobility model configuration

Parameter	Value	Units
v_position_x_interval	0-278	km
v_position_y_interval	0-278	km
v_speed_interval	100-400	m/s
v_pause_interval	0-1	s
v_walk_interval	2-60	s
v_direction_interval	-180 180	degrees

3.1.4 Networked Effects, Growth and Adaption

As described in Section III, topology optimization and control must provide timely control to provide a stable fabric for higher-level network protocols and processes [9]. In effect, successful topology control needs to balance mobility effects, optimal link configuration, allowed combinations and reconfiguration costs. Some attributes of topology stability include:

- Re-computation interval
- Number of link changed
- Link duration
- Path availability

3.1.5 Measures Of Performance (MOP)

Distributed networked operations leverage the diversity of dissimilar units and the rapid dissemination of intelligence to support commanders' intent and operational objectives. Similar to wireless sensor networks (WSN), tactical airborne networks provide the operator with battlespace situational awareness to facilitate target searching, tracking and identification. As a result, wireless sensor networks must be scalable and

robust with minimal susceptibility to partitioning [56]. Consequently, performance metrics of interest are:

- Node connectedness
- Partition events

Additionally, from network and complexity theory, we compute four proven measures that quantify topology effects, growth and adaption performance [1, 97, 98].

- Clustering coefficient - a measure of network cohesion, the ratio of the number of actual links between neighbors to the total number of possible links between neighbors. Therefore, a fully connected graph would have a ratio of one.
- Core number (vertex) - largest integer c such that the vertex has degree > 0 when all vertices of degree $< c$ are removed. Higher values indicate improved node resiliency to a link failure.
- Betweenness (edge) - the measure of total flow an edge carries as computed from all pairs with flow to/from the edge where high values indicate bottlenecks.
- Characteristic Path Length (CPL) - the average (or median) path length between two nodes averaged over all pairs of nodes. Higher values indicate low-density graph topologies (i.e., less overlap between nodes), which implies fewer link forming opportunities per node. For multi-hop networks, achieving the lowest CPL possible through optimal link selection is crucial to avoiding undesired latency due to packet forwarding. Combat networks should have CPLs on the order of $\log k$ or shorter [1].

3.1.6 Assumptions and Results Disclaimer

In this section, we discuss the impact of several practical considerations on the different strategies. This experiment made several simplifications to the problem domain. For completeness we list them below:

- Two-dimensional grid search space
- Fully-connected network initialization
- Undirected edges
- Static communication latencies (per node and hop)

- Random way-point mobility
- Lossless channels
- No aircraft or environment obscuration
- Symmetric/fixed-rate throughput
- k-connected, m-dominating set topology computation
- Global queries
- Fully-cooperative nodes
- Assumed successful node detection and acquisition
- RF chain supports multiple access
- Non-uniform and sparse node dispersion

3.1.7 Simulation and Model Organization

The high-level programming language MATLAB was selected to minimize model development time and integration into a discrete-event time simulation. The following sub-sections summarize the problem formulation and implemented software.

Table 6. Software design and function

Model name	Purpose
main.m	Generates the experimental runs
xp_config.m	Initialize experimental variables
mobility.m	Random Way-point Mobility model
time_series_data.m	Node position interpolation per time
k_connected.m	Compute deterministic topology
test_animate.m	Time-series plot generation
post_process.m	Results plots

3.1.8 Problem Formulation and Visualization

Graph theory provides an easy and systematic way to model topology control. Since the transmission range is computed as Euclidean distances between vertices, a grid graph is well suited to represent a wireless P2P network. The nodes in the

network are represented as vertices and communication links as edges. Each vertex is a row and column entry in the two-dimensional search space (see Fig 30). Although an airborne network would require a three-dimensional search space to include atmospheric effects propagation differences, this experiment utilizes a two-dimensional grid graph since the topology computation methods are fundamentally identical.

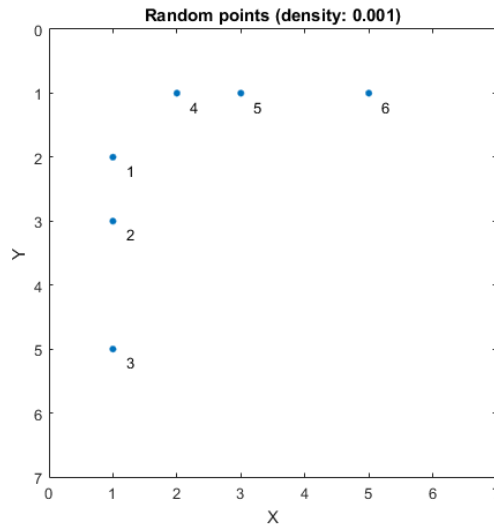

Figure 30. X×Y search space example

All-Pairs Shortest Paths

Edges can be calculated and constrained in a number of ways. For simplicity, this experiment does not integrate a free space propagation computation. However, a critical transmission range value is assigned and compared to a pairwise distance computation (pdist) to limit allowed edges to viable configurations. The Chebyshev distance between two vectors or points p and q , with standard coordinates p_i and q_i , respectively, is:

$$D = \max(|x_2 - x_1|, |y_2 - y_1|) \quad (10)$$

Convex hull

In addition to the grid graph plots, we found it useful to visualize our core number computation during run replay through shading (see Fig 31). This was accomplished using a convex hull function (also called convex envelop and denoted by $CH(X)$ in some texts). The convex hull for a set of points X in real vector space is the minimum convex set containing X . It is represented by a sequence of the vertices of the line segment forming the boundary of the convex polygon.

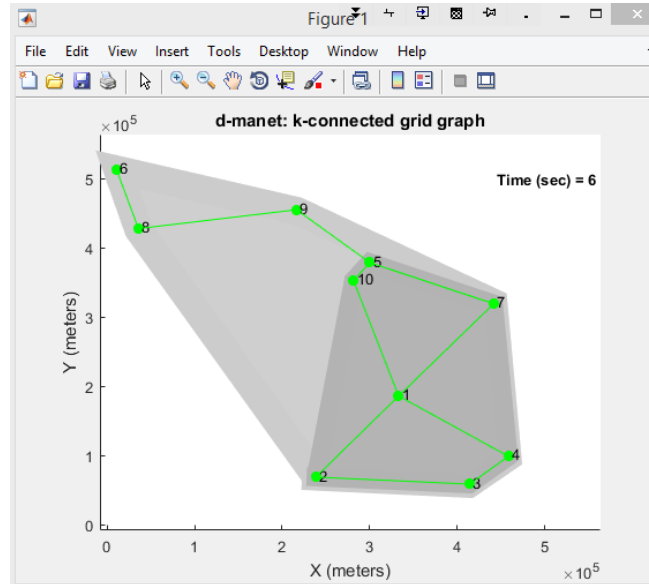

Figure 31. Convex hull shading example

Topology Computation and Management

As described in the section above, the algorithm design goals included ensuring path multiplicity and connectedness. Establishing a virtual backbone in the tactical airborne network is an important issue because it reduces unnecessary message transmission or flooding in the network related to path and route discovery. In this

approach, we construct a virtual backbone by finding the degree-bounded minimum weight spanning tree (dMST) - also known as a degree-constrained (DCMST) in some texts. The dMST problem is NP-Hard with some specific variations solvable in polynomial time [99]. Also, augmenting the tree to achieve k-connectivity is NP-Hard [100].

The dMST problem formulation (eq 11) below by [99] seeks to maximize the selected number of edges in the graph $G = (V, E)$ with $V = |V|$ for constraints (eq. 12 and eq. 13).

$$\max \sum x_{ij} \quad (11)$$

$$\sum_{e_{ij} \in \delta(v)} x_{ij} \leq b_v \quad \forall v \in V \quad (12)$$

$$\sum_{e_{ij} \in \Psi_l^V(m)} x_{ij} \leq l - 1 \quad \forall v \in V \quad (13)$$

where

$$3 \leq l \leq V$$

$$x_{ij} \in 0, 1$$

The first constraint b_v is the set of adjacent edges to any vertex v (eq 12). The second constraint Ψ^V represents the set of all cycles in the complete graph, where Ψ_l^V is the subset of V cycles of l length minus one edge (eq 13). The specific lexicographically ordered cycle being computed is denoted by m . In both constraint equations, the x_{ij} variables are summed over the corresponding edges.

To minimize computation, the authors of this article [99] apply the following search space optimization. Since cycles are disallowed in a dMST, the minimum number of edges must be equal to the number of vertices minus one (eq 14). To satisfy the DMST degree property, there must be at least one edge (eq 15). Lastly, the dMST endpoints must have exactly one edge, thus, the constraint (eq 13) can be re-written by substituting (eq 14) for l which yields (eq 16).

$$x_{ij} \leq V - 1 \quad (14)$$

$$\sum_{e_{ij} \in \delta(v)} x_{ij} \geq 1 \quad \forall v \in V \quad (15)$$

$$\sum_{e_{ij} \in \Psi_{v-1}^V(m)} x_{ij} \leq V - 2 \quad \forall v \in V \quad (16)$$

A minimum length (weight) spanning tree was preferred in order to prolong path availability given the high-rate of node mobility inherent in an airborne network, but increases latency for end-to-end applications.

Next, the connected vertex edge list is then expanded to form a k -connect graph. A k -connected is an m -dominating set graph. Our graph is computed by finding two dominating sets from a weight ordered set of vertices, and then by connecting them. The weight order is found by taking a breadth first search of all known vertices.

Finally, edges that exceed the CTR and/or the degree are removed. The algorithm pseudo-code and sample output visualization below (Algo 1 and Fig 32) summarize the topology construction operations.

k-connected 2-dominating set algorithm

```
1: function PDIST(vertex_xy, calc_method)
2:   Return Euclidean distances between vertices
3: end function
4: while  $\forall \text{nodeList} \{ \exists \text{weight} > \text{ctr} \}$  do
5:   weight  $\leftarrow$  0
6: end while
7: function DMST(nodeList)
8:   Return edgeList
9: end function
10: function K_CONNECTED(vertex_xy)
11:   Perform BFS on  $\forall \text{nodes}$ 
12:   Sort  $\forall \text{nodes}$  into 2 sets, where odd  $\notin$  even
13:   Compute an odd  $\cup$  even edge_list
14:   Return edgeList  $\supseteq$  (odd  $\cup$  even)
15: end function
16: Find edgeList  $\supseteq$  {dMST, K_CONNECTED}
17: while  $\forall \text{edgeList} \{ \exists \text{weight} > \text{ctr} \}$  do
18:   weight  $\leftarrow$  0
19: end while
20: while  $\forall \text{edgeList} \exists \{ \sum \text{edges} > \text{degree}_{max} \}$  do
21:   weight  $\leftarrow$  0
22: end while
```

Algorithm 1. Topology computation pseudo-code

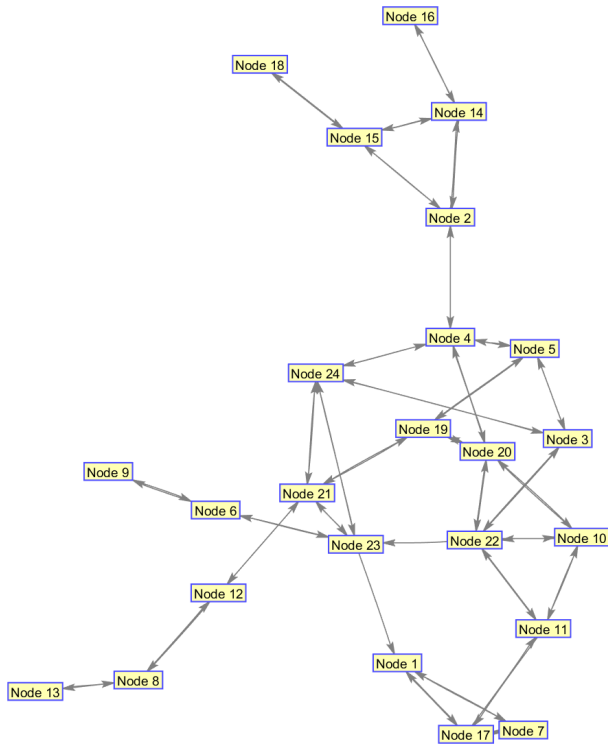
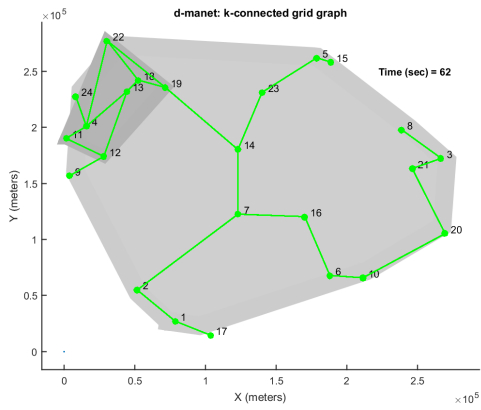
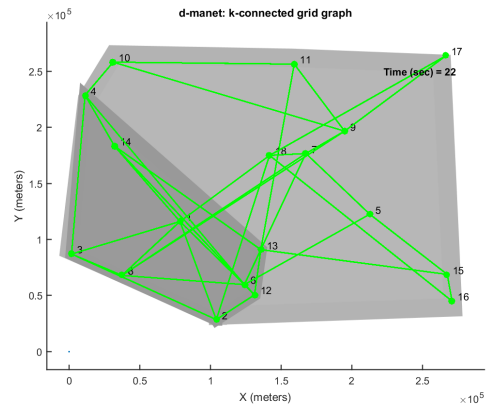

Figure 32. Topology computation output visualization



(a) Block 1



(b) Block 2

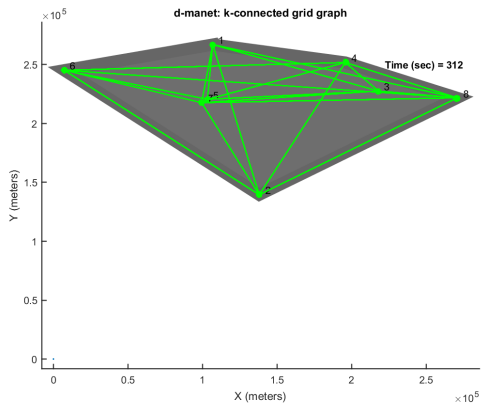

(c) Block 3

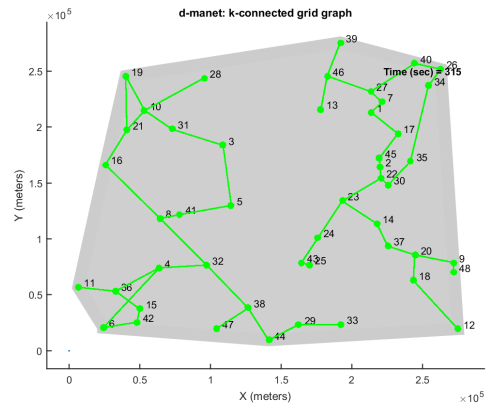

(d) Block 4

Figure 33. ATC simulation visualization examples

3.1.9 Analysis of Results

In summary, we found the topology reconfiguration interval and the number of nodes in the graph to be statistical significant to the following measures:

- Clustering coefficient
- Core number (vertex)
- Betweenness (edge)
- Characteristic Path Length (CPL)
- Number of partition events

As expected, each block of runs yielded very different results over time related to our performance measures (Fig 42), which supports our hypothesis that an optimal topology computation method must adapt to available hardware resources, mobility and network size.

Block 4 exhibited the greatest number of stability (partition) events ($\alpha = 0.99$, $\mu = 1.61$, $\sigma = 0.62$). Significant to the result (Table 7) was the following design attributes: 1) reduced critical transmission range, 2) reduced nodal degree, and 3) the long interval reconfiguration time. As compared to the Block 3 result, which boasted two times as many channel resources each with three times the link range and an identical reconfiguration interval (per table 2), the Block 4 structural topology was 62% less resilient and exhibited more than $4\times$ the susceptibility to traffic congestion. Thus to avoid network partitioning, the preliminary experimental results suggest that current intra-flight based communication architectures are likely to require additional channel resources to completely fulfill the future scalable “combat cloud” capability concept.

Also, the Block 4 result illustrates the criticality of early design choices related to hardware and resource allocations, since antenna performance and number of channels clearly played a significant role in network scalability and communications quality. For acquisition communities at large, our results suggest that incremental network capability development approaches will be less efficient and exhibit greater overall

life-cycle cost unless early increments explicitly provision for future capabilities. Further, programs must carefully consider the cost of backwards compatibility since mixed communication architectures are likely to be burdened with additional process communication overhead and greater topology computation complexity.

Yet another programmatic challenge, since susceptible links are likely to experience reduced range performance, highlights the real-world military test adequacy problem of how to best characterize network performance in relevant hostile electromagnetic environments at realistic force strength. Due to the inherent difficulty and cost of performing large scale open-air tests, it is more likely that test communities will rely on constructive simulation. However, when it comes to answering questions about scalability of network capabilities, model fidelity will need to be carefully considered. For example, we observed spatial diversity violations in our simulations that require the integration of a TDMA physical channel model to more accurately estimate the realized end-to-end topology throughput.

Further, since topology control capabilities have yet to be standardized for airborne direction MANET, programs are likely to experience many challenges related to availability of open-source high-fidelity models.

Table 7. ATC experiment results summary

Metric ($\alpha = 0.99, \mu, \sigma$)	Block 1	Block 2	Block 3	Block 4
Disconnected nodes	0, 0	0, 0	0, 0	0, 0
Graph partitions	1.37, 0.75	1, 0	1, 0	1.61, 0.62

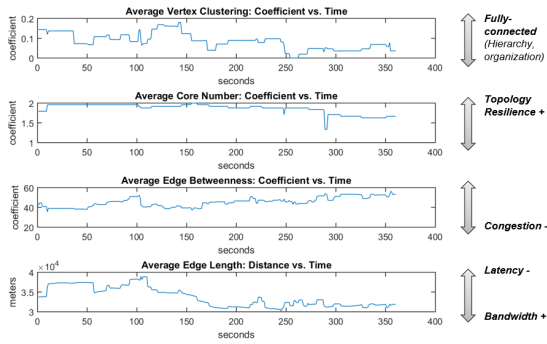

(a) Block 1

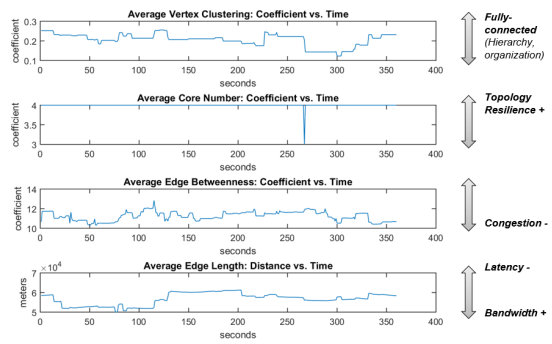

(b) Block 2

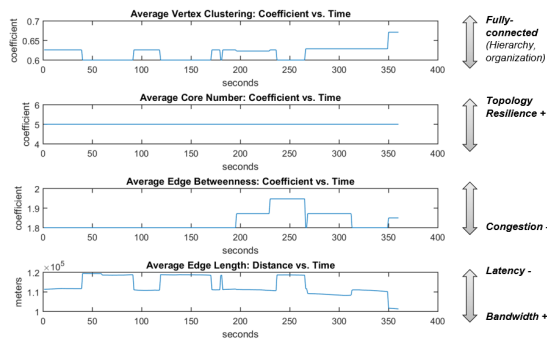

(c) Block 3

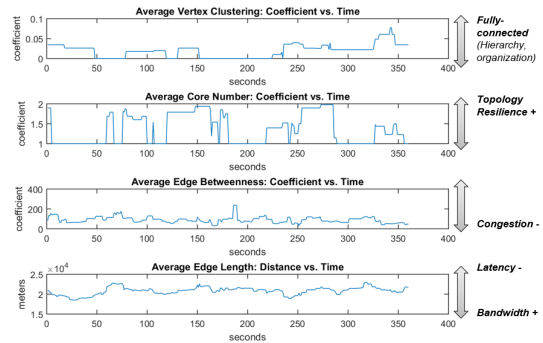

(d) Block 4

Figure 34. ATC experiment results by block

3.1.10 Experiment Conclusion and Improvements

We note that the current ATC approach can be further improved by reducing end-to-end path changes between dMST computations, a method known as dynamic dMST computation. Simply put, dynamic dMST computation considers the previously computed dMST during computation of a new optimal dMST. Also, we plan to upgrade topology control algorithms with capabilities to dynamically optimize end-to-end path cost for different traffic heuristic approximations to demonstrate cognitive networking capabilities.

Based on our results (Table 7), to deploy scalable and self-organizing networks, future topology management and control designs will require increased and affordable cognitive and self-organizing attributes that allow for a seamless transition between physical network structures. In the near-term, more comprehensive topology control and management modeling and simulation is needed to better define scalable, reliable and communication efficient topology control requirements to enable cooperative and autonomous networking capabilities.

3.2 Channel Assignment Experiment

This section focuses on the theoretical aspects of channel contention and TDMA schedule efficiency. This experiment extends the previous experimental design (see Sect 3.1, Table 3) to study the impact of differing channel scheduling methods and antenna attributes on multi-hop/multi-channel D-MANETs.

3.2.1 Experiment Purpose and Goals

As described in the introduction, many existing DoD aircraft and weapon systems are developed using platform-centric top-down design approaches that are frequently cost-prohibitive to install on new aircraft, thus, depriving the warfighter of NCW

capabilities. Although agencies like the DoD's Joint Interoperability Certifier (JITC) are chartered to assist programs in identifying requirements to ensure interoperability is built into systems from the start, system certification does not guarantee network scalability nor cross-platform performance thresholds needed to develop robust solutions. Further, unlike most space systems which include lower-layer testing, frequently airborne system interoperability testing and certification is based solely on message-centric approaches that result in late discovery of scalability and performance issues. Consequently, a goal of this experiment is to emphasize the importance of lower-layer military standards to support interface development and early lab testing to better address the challenges of network dissimilar platforms.

The main goal of this experiment is to qualify channel assignment properties and target hardware performance thresholds of importance to topology control protocol design. Although this experiment utilizes centralized channel assignment computation methods, which does not account for directional channel switching and distributed control system communication cost, it does provide valuable multi-hop (or forwarding) delay trend information, in addition to, the interference reduction trends on D-MANET topologies resulting from differing channel assignment scheduling methods.

3.2.2 Assumptions and Results Disclaimer

In addition to the Sect 3.1.6 assumptions, this experiment made the following additional simplifications to the problem domain:

- Channel schedule computed with centralized methods
- Directional links do not exercise power control mechanisms

3.2.3 Simulation and Model Organization

The following sub-sections summarize the additional and updated functions needed to simulate interference and time-division multiplexing.

Table 8. New and revised software

Model name	Purpose
main.m	Updated fitness functions
accum_intrf.m	Returns worst case interference per link
sig_doa.m	Computes link direction-of-arrival per partition
test_animate.m	Updated time-series plot animation
post_process2.m	Computes multi-hop forwarding metrics

3.2.4 Problem Formulation and Visualization

Graph theory provides an easy and systematic way to model both the channel time-partition assignment and spatial collision domain problems. As previously described in Sect 2.7.1, the channel assignment problem can be visualized using vertex coloring (see Fig 35). Depending on the method used, vertices are first sorted by degree of other criteria. Next, common to all techniques discussed, is the step of solving for a clique, which is then followed by repeated color assignment. In this experiment, we studied the second-order effects related to three different channel assignment techniques, which included:

- Greedy: Vertices sorted by descending order of degree
- Random: Vertices randomized followed by sequential color assignment
- Optimal: Brute force recursive search for best possible coloring

Distributed one and two-hop neighbor based channel partitioning protocols may not eliminate all channel contention due to reduced solution quality. Thus, this

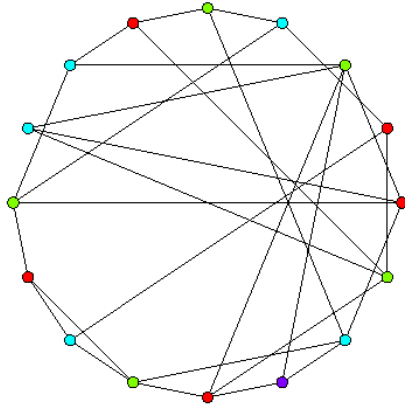

Figure 35. Coloring algorithm output visualization

experiment implements angle-of-arrival calculations by collision domain (i.e., color) to develop cumulative signal interference metrics to study the impact of different computation techniques. In the following example (see Fig 36), dashed and dotted lines are used to represent channel contention at the receiver aperture and main-lobe respectively with respect to the “teal” time partition. Due to link representation as a single line, we note that the visualization can be misleading (i.e., contention may be greater than illustrated), however, computed results do account for the two-way (or full duplex) links.

3.2.5 Design of Experiments (DoE)

This paper presents results from a screening design conducted to support a reduction of statistically non-relevant factors and to guide future model fidelity improvement priorities. The following table summarizes the additional factors used in this simulation excursion:

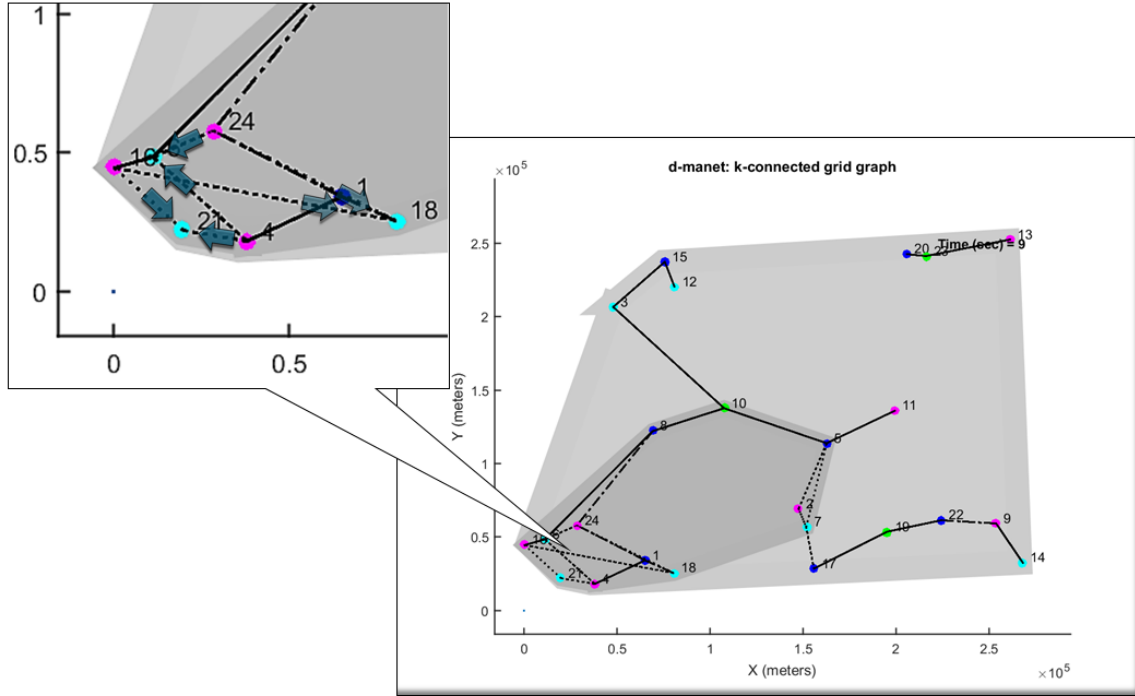

Figure 36. Domain collision visualization example

Table 9. Channel assignment experiment configurations

Parameter	Block 1	Block 2	Block 3	Block 4
Aperture arc	120 deg	90 deg	180 deg	180 deg
Main lobe arc	20 deg	16 deg	50 deg	60 deg
Algorithm	Optimal	Greedy	Random	Optimal

3.2.6 Analysis of Results

In summary, we found the topology reconfiguration interval and channel assignment algorithm to be statistically significant to the following measures and factors:

- Number of time-division multiplexing partitions (or colorings)

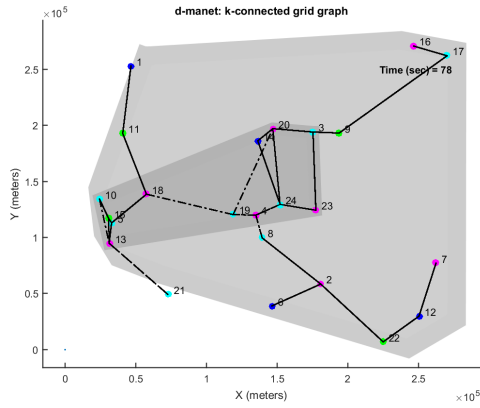

(a) Block 1

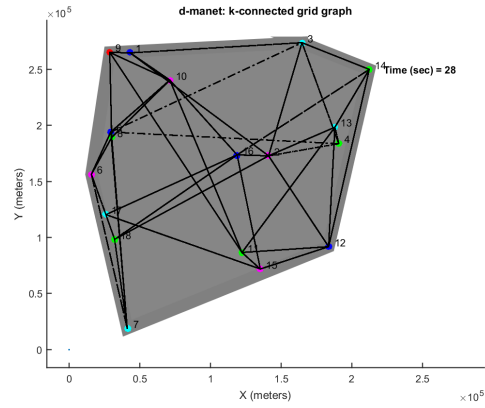

(b) Block 2

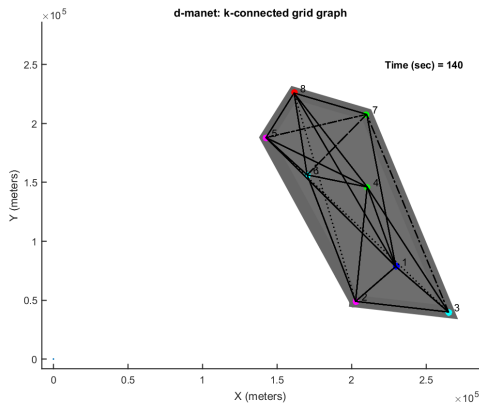

(c) Block 3

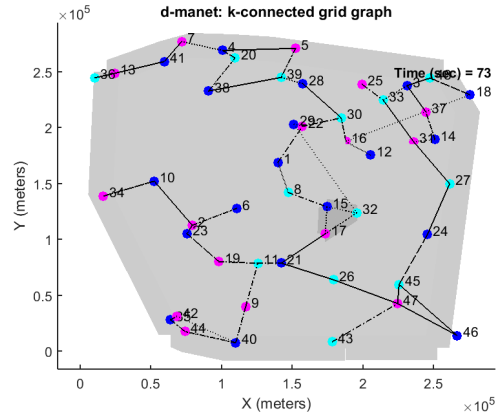

(d) Block 4

Figure 37. Channel assignment simulation visualization examples

- Signal interference at main lobe
- Signal interference at aperture

Further, the following properties were significant to the signal interference and the mean partition count:

- Propagation distance (or CTR)
- Max k-degree
- Number of nodes (or graph sparsity)

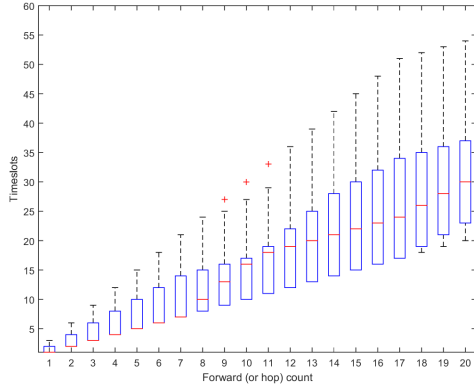

(a) Block 1

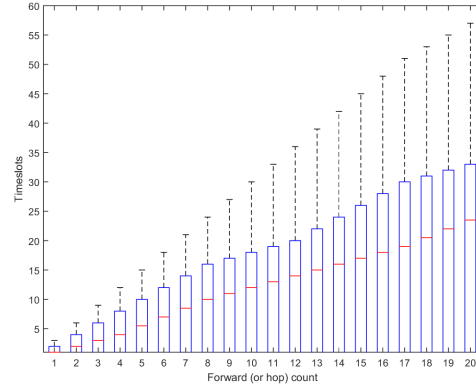

(b) Block 2

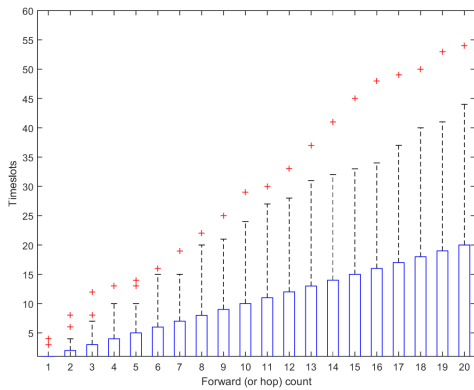

(c) Block 3

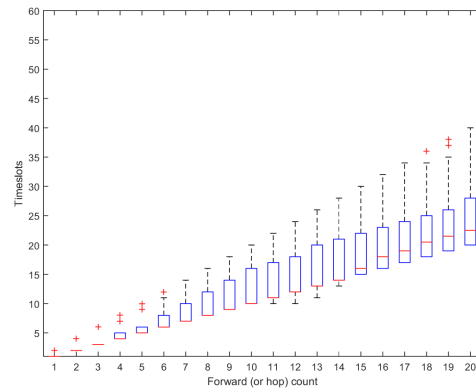

(d) Block 4

Figure 38. Channel assignment experiment results by block

3.2.7 Experiment Conclusion and Improvements

Based on our results (Table 10), this experiment validates the need for precision power management mechanisms, in addition to, lower-layer feedback (in the form of SINR heuristics) to formulate adaptable and efficient topology control optimization. More importantly, this experiment showed that 1-hop and 2-hop neighborhood detection type protocols are not well suited for D-MANET and that new spatial re-use time-division approaches are needed.

Block 4 exhibited the lowest forwarding delay and best schedule efficiency. This

Table 10. Channel assignment experiment results summary

Metric ($\alpha = 0.99, \mu, \sigma$)	Block 1	Block 2	Block 3	Block 4
Schedule efficiency (colorings)	3.80, 0.402	5.13, 0.480	4.59, 0.491	3.00, 0.000
Forwarding delay (timeslots)	1.52, 0.182	1.93, 0.276	1.60, 0.239	1.29, 0.053
Signal interference at aperture (%)	0.37, 0.070	0.24, 0.046	0.14, 0.080	0.09, 0.027
Signal interference at main lobe (%)	0.49, 0.074	0.63, 0.052	0.51, 0.110	0.71, 0.044

can be attributed to the low k-degree propagation attributes combined with the scheduling algorithm solution quality. However, in the simulation the optimal computation method benefits from global information, which would be very costly in a distributed message passing environment. Despite the time-division partitioning, we note that this block shows substantial interference impact due to wider beamwidth.

Lastly, per Sect 2.7.2 findings, cross-layer multi-channel DMAC protocols have yet to be developed. When protocols are developed, they will need to overcome the increased variability in forwarding delay resulting from non-sequential time partitions.

IV. Future Work

Moving us towards the overarching research goal to demonstrate a highly-scalable and reliable topology control protocol design that satisfies the salient features of D-MANET, is the task of modeling a basic set of communication services to support the transformation of fixed configuration P2P tactical networks (as described in Section 2.2) into self-forming, self-managing distributed autonomous systems.

In addition to the physical layer design constraints of the communications channel, this chapter provides greater detail related to message passing required to communicate resource availability among different nodes to form a scalable self-organizing network capability. In practical experiments, it has been observed that a large amount of time can be required to join an offered ad-hoc network and establish connectivity, forming a transitional network structure that must be morphed into an optimized structure by topology control [48]. Furthermore, network split and merge operations can be time-consuming, contributing to route bottlenecks impacting protocols and applications.

4.1 Network Management and Data Routing

Scalable airborne networking demands cost-effective and decentralized ad-hoc management techniques like those developed by [101]. The following paragraphs summarize the respective benefits to our problem domain of using service-driven, best-effort, and network formulation schema. Specifically, the authors introduce the “net_id” concept, which is an attribute (a number) assigned to uniquely identify an ad-hoc network (a group of strongly connected components) and the hosts’ membership.

4.1.1 Network Identity

A technical strength of their approach is that it does not depend on a master or cluster head controller and, hence, does not require a heart beat signal nor beacons reducing topology control communication costs. Each node is required to store the “net_id” variables while the network is active or until a time-to-live timer expires, in which case, the “net_id” is canceled.

When we consider maintaining strike package integrity, for example, the quality of remembering a network related information during a momentary departure due to threat avoidance makes this protocol well suited for the airborne tactical environment. Additionally, nodes may maintain multiple network identifiers, similar to the way IEEE 802.11 accomplishes this using the service set identifier (SSIDs), simply by storing each new network identifier, which is advantageous to transient operations. The question of how long to remember a network is a question of resources (memory) and utility of information associated with the network identifier over time. For example, a heterogeneous network configuration that requires members to discover available resources, services are state-full, and data providers must be learned, could benefit enormously as compared to a homogeneous network case where resources are standardized, services are stateless, and data providers use publish/subscribe mechanism. For simplicity, we consider the latter case.

The major difference between this approach and the many others discussed in the available literature is that the mobile network is treated as the domain system, with a fixed identifier, versus other location-dependent address systems that focus on the nodes themselves. As the authors point out, using a network identifier is advantageous to MANET for the following reasons:

- An administrative domain preserves locality of communication
- Facilitates efficient intra- and inter-domain routing schema
- Permits quantification of MANETs joined over time

Intra- and inter-domain routing is especially relevant when we consider the goal to transform the small (2-4 ship) tactical networks into a larger distributed operations network. As previously discussed in Sect 2.4, scalable routing protocols are a non-trivial aspect of MANET design. Recall that the reactive protocols perform route discovery by flooding the network, which delays traffic until new routes are established. Alternatively, proactive protocols maintain route tables between some or all nodes. However, when the topology changes a flood of route update traffic is produced. Other techniques include the hierarchical and coordinate-based approaches, which do not flood the network but decrease resilience to failures, introduce overhead, and increase complexity [102]. Thus, the “net_id” is advantageous because it adds a mechanism to control latency by domain (intra-flight and inter-flight) enabling wide-area network flows through structured overlays of smaller MANET networks.

For example, the Virtual Ring Routing (VRR) is a network routing protocol implemented directly above the link layer that could efficiently provide both point-to-point and overlay routing (using distributed hash tables) between MANETs [102]. One major difference of this protocol is that it does not rely on an underlying routing protocol to provide the perfect connectivity between all pairs of overlay nodes. One of the goals of combining DHT with wireless network routing is to route around discontinuities and link failures. Unlike other DHT methods, VRR populates the fingers not with node end-points, but the virtual set of paths that route through it. Applied to ad hoc network management framework by [101], the fingers would be “net_id” MANETs. Keeping the DHT updated works similar to other implementations. Each node maintains a small number of paths pro-actively to its neighbors in the virtual ring. These paths can be used to forward messages between any pair of nodes and they can be set up and maintained without flooding.

4.1.2 Join

The “net_id” implementation splits the join operations into two steps, an active search and passive search. The first step, active search, requires the node to broadcast a join message to immediate one-hop away neighbors. The node then listens for a reply carrying a network identifier. Their implementation describes a “join timer” parameter to allow tuning of this state.

Accordingly, in the proposed airborne D-MANET framework, we recommend an initial “join timer” setting within $\mu + 1\sigma$ the time to cycle through the PAT link states described in [53]. We considered that the effect of setting this value too low would result in the many nodes creating and advertising new network identifier with join-ack messages. However, setting this value too high has the effect of increasing new network formulation time. Thus, careful tuning is required to balance communication efficiency vs. network discovery time.

The authors outline two versions for the second step of the join procedure. In version A of the algorithm, the first available network is adopted and the join procedure is exited. We selected version B of the algorithm to implement, because it best satisfies the distributed operational goal to provide improved service and/or information discovery opportunities. In version B of the algorithm each node continues to listen for join ack messages, but a “delay timer” countdown is also started. In version B, for a new network identifier to be created, both the join and delay timers must expire. Then, the newly created network is made public by broadcasting. However, if a node has received one or more network identifiers during the delay timer windows, it adopts the received identifiers (vs. creation of a new network identifier). Consequently, if multiple ad-hoc networks were adopted, then the node becomes a de facto gateway. Version B was found to have better performance related to reduction of split/merge event occurrence in multi-hop and high node density environments [102]. However

the cost to achieve this behavior was in terms of increased execution time, defined as:

$$t_{execution} = \sum t_{join} + t_{delay} + t_{formation} \quad (17)$$

Where the formulation time is equal to the time to compute and broadcast the network identifier to the nearest neighbor:

$$t_{formation} = \sum t_{computation} + t_{broadcast} \quad (18)$$

Since algorithm (version B) waits to acknowledge network identifiers until the join timers expires, the best case time is:

$$t_{execution} = \sum t_{join} \quad (19)$$

The worst case time is:

$$t_{worstcase} = \sum t_{join} + t_{delay} + t_{formation} \quad (20)$$

4.1.3 Split and Merge

Airborne networking benefits from a k-connectivity constraint in the topology control design to minimize network fractures (or splits) resulting from any single link failure, however, partitions can not be completely eliminated when there exists a disproportional search space in relation to node density and CTR performance. As

we discussed in the VRR approach, it is essential to maintain distinct network identifiers to facilitate explicit inter-domain routing. Since a departing node maintains a network identifier until the time-to-live timer expires, a strongly connected partition of multiple active nodes is likely to circumvent the network identifier timeout (see Fig 39). Thus, in this circumstance there would be two or more strongly connected components operating with the same network identifier. This is problematic because learned services and information providers may now be unreachable and, thus, unresponsive. Also, the network identifier conflict results in inter-domain routing ambiguity (as depicted in Fig 40), which results in lost traffic and general network instability.

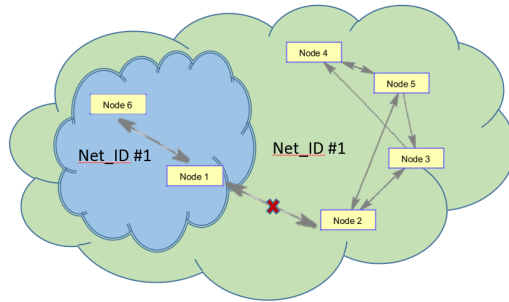

Figure 39. Duplicate network identifier example

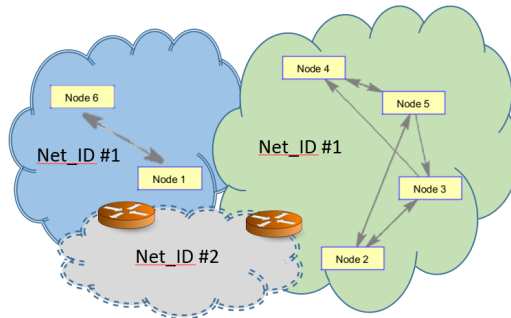

Figure 40. Ambiguous network routing example

Recall that VRR avoids the problems of location-dependent addresses by using

unique fixed identifiers to maintain the map of paths to virtual neighbors. To satisfy this property, after a gateway node detects that MANETs are overlapping, it must distribute a message to all its peers to de-conflict the network identifier by either generating a new network identifier or by relabeling the nodes with a current network identifier. Although a merge operation is beneficial to intra-domain service and information provider discovery, it does increase traffic latency and route maintenance cost. Applied to the VRR link-layer routing context which supports both virtual node and point-to-point network identifier routing, a constant number of hops can be guaranteed by establishing a maximum allowable node limit parameter.

An overarching challenge to “combat cloud” network design is how to minimize latency within a small intra-flight tactical network, yet provide scalable ad-hoc MANET routing. To achieve traffic and network management performance goals, we anticipate future designs will set limits dynamically through use of a traffic heuristic to facilitate optimization within each independent intra-domain enabling “...mission-aware trades involving capacity, latency,...” [6]. In fact, one of our research goals is to demonstrate that a directional MANET could reliably adapt and achieve conditions favorable to fifth generation tactical aircraft equipped with semi-autonomous cooperative avionics and services.

4.2 Protocol Performance Modeling and Evaluation

As described in the text, airborne multi-channel/multi-hop D-MANET networks are complex. To harness the emerging technology gains, performance modeling and evaluation are a crucial next step in practical protocol design. Unfortunately no standardized techniques exist to-date to formulate topology control process behavior and practical limitations in a distributed manner for a hostile and/or benign environment. This open issue can be attributed to a lack of flexible analytical simulation

tools and models supporting cross-layer effects evaluation given imperfect channel state information (CSI) and network state information (NSI) [21, 71, 103]. Many naive simulations omit channel overlaps, switching and coordination costs. As such, imperfect CSI/NSI modeling is not only important to network capacity upper bound formulation, but also to deriving the amount of interference caused to other nodes allowing holistic evaluation of dissimilar topology control design solutions [27, 104].

Packet-based communications dependencies ultimately define asynchronous protocol performance and process behavior, since a scalable MANET autonomous topology control protocol is inherently a distributed process susceptible to communication effects [23, 40, 48, 64, 67, 104–106]. For instance, the second-order effect of a link failure (due to nodes moving out of range of each other or due to channel contention), which results in repeated packet delivery timeout and subsequent route failure. Detection of the failed route causes reactive topology control to replace the failed route with a new route that may have very different round trip times (RTTs). Given a large variance in RTTs, retransmission time out (RTO) increase per formula (21), which may result in unsatisfactory network performance. For example, channel access, network management and routing protocols all depend on timely feedback to establish connections and determine the least-congested routes. The RTT_{est} is the exponential average of RTT samples observed and RTT_{dev} is the standard deviation [50].

$$RTO = (RTT_{est} + 4 \times (RTT_{dev})) \quad (21)$$

4.2.1 Layered Framework Design Concept

A simulation framework must include both time and event-based model effects (see Fig 41) to discover congestion impacts on control process behavior, in addition to, estimating the communication cost vs. process effectiveness gain ratio. For com-

munication patterns that congest the network the effective bandwidth is the link bandwidth scaled down by the degree of congestion [54].

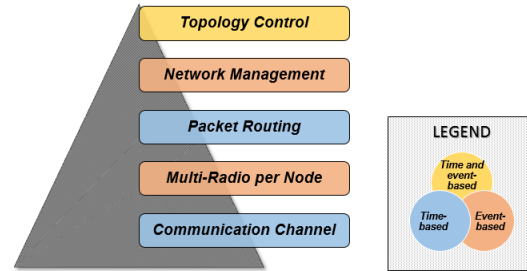

Figure 41. Simulation layers

Moreover, for a given topology structure the communication costs can vary based on the layout of nodes forming the topology [10]. To ensure simultaneous coherence of the topology control operation, the network must be able to sustain the associated state-update messages.

Modeling the decentralized network control plane is key to practical protocol design, since the control plane is a finite shared resource made up of several competitive communication processes of equal priority, which incidentally are invoked with every network topology change. For D-MANET, the competing network services include: 1) channel scheduling, 2) neighbor discovery, 3) network management, 4) routing, and 5) topology control.

To support robust ATC protocol design and evaluation leading to prototype design and hardware-in-the-loop (HIL) simulation, we propose extending the P2P model developed by [53] to support the following capabilities of practical interest:

1. Topology control
 - Timeliness of adaptive and reactive link scheduling
 - Structure performance
 - Optimization quality

- Convergence time
 - Distributed methods, scalability and cost
2. Network management
 - Cognitive capabilities
 - Flexibility
 - Formulation time
 3. Packet routing
 - Domain schema
 - Bounded multi-hop
 - Neighbor discovery
 - Network delays (forwarding and congestion)
 4. Multi-radio per node
 - Logical link control
 - Pointing, acquisition and track
 - Channel assignment strategy
 - Load balancing
 - Link condition awareness (radio to router)
 5. Communication channel
 - Antenna type, number and performance
 - Beam steering agility
 - Contention
 - Link stability and failure detection

4.2.2 Practical Considerations

Simulations must make simplifications for practical reasons. However, for an airborne domain, an assumption that all nodes are the same is not practical and should be avoided. Also, three-dimensional (3D) mobility and antenna asymmetric spatial and frequency response performance, as illustrated by Fig 42b and 42a, are frequently

omitted [40]. Further, most modern transceivers integrate multiple dynamic behaviors for performance gains like dynamic rate adaption, which allows the transmission bit rate of the data changes in response to channel SNR and utilization to improve both throughput and minimize packet delivery delay [107, 108]. In addition to co-channel interference, another source of performance degrading interference and noise is due to MIMO channel bonding (or subcarrier) effects and estimation error [12, 109].

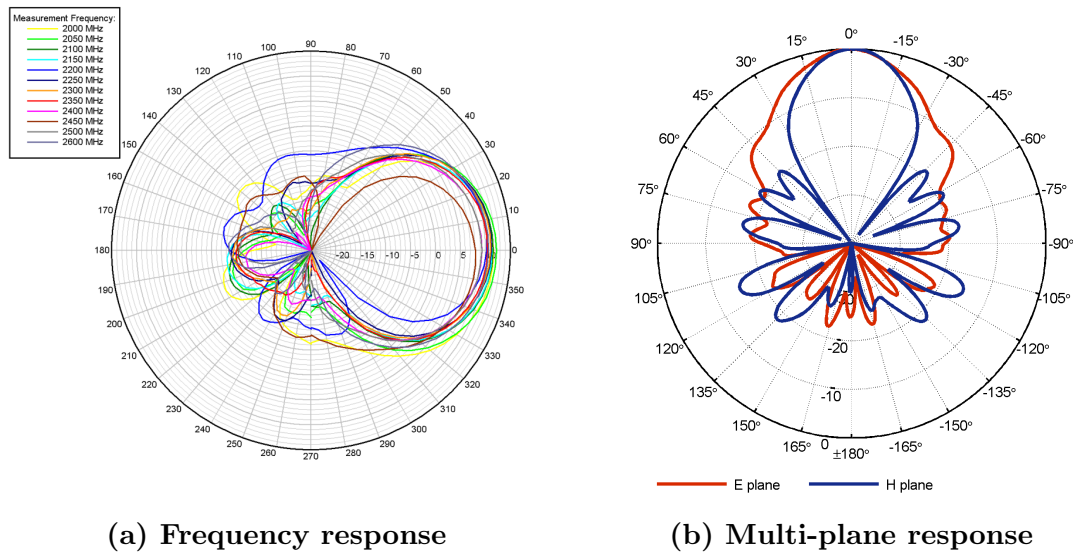

Figure 42. Asymmetric antenna gain properties

Lastly, to strengthen modeling accuracy and secondary detail discard decisions more historical channel measurement information for electro-magnetically hostile and high-mobility airborne environments is needed. Thus, many opportunities exist to improve simulation and model fidelity to support improved ATC protocol design and performance benchmarks.

V. Findings and Recommendations

In this work, we detailed the many technical design challenges related to the transition of tactical (intra-flight) datalink capabilities to scalable enterprise-wide (inter-flight) communication services enabling the NCW “combat cloud” concept. In summary, this thesis discussed the following design features and trade-offs:

- Solution quality vs. computation and communication cost
- MIMO antenna capacity gain opportunities from improved signal spatial diversity
- Suitability of commercial MANET standards for the airborne domain
- Evidence for high-efficiency non-IP based protocols
- Use-case for multiple and specialized routing protocols
- Performance improvement opportunities through cooperative avionics approaches
- Directional antenna beamforming performance, gain, and switching cost on ATC
- Emerging channel efficiency improvement opportunities with hybrid-type DMAC protocols
- Linear to dynamic topology upgrade challenges
- Impact of multi-hop forwarding costs in terms of latency
- Scalability and reliability improvements with adaptable topology control and cross-layer designs
- Overarching effects of early design choices and information dependencies
- Simulation and modeling fidelity challenges
- Self-forming and organizing distributed system challenges

This work found that a universal best topology control and power optimization is not possible, necessitating greater dependence on adaptive and cognitive network capabilities to overcome the unpredictable and dynamic structure of airborne D-MANET.

Additionally, this work showed that one type of performance optimization may come at the expense of other network goals. The upper and lower performance bounds

of an autonomous topology control optimization and management protocol are dominated by solution quality, communication architecture assumptions, and constraints applied at each layer. Efficient formulation of an optimal topology solution within this region is a complex problem, because the topology control protocol design must balance available network resources, protocol stack performance, and application demands.

Lastly, we proposed a D-MANET layered framework concept to support comprehensive protocol design, supporting improved estimation of communication cost vs. process effectiveness gains.

5.1 Parting Shots

To expedite capability fielding, we recommend the following technology risk reduction activities:

- Incentivize contractor participation in military standards development
- Verify viability of directional multi-channel hardware
- Guide an enterprise-wide technical baseline decision process
- Publish a D-MANET protocol stack and network services RFC
- Develop high-fidelity simulation and reference models
- Draft non-proprietary communication and network standards
- Build mature prototypes with well-defined interfaces
- Perform simulation with HIL
- Complete field tests to validate technology suitability and effectiveness
- Provide programs with technical basis information to support improved cost estimation

Bibliography

1. J. Cares, *Distributed Networked Operations: The Foundations of Network Centric Warfare*. Alidade Press, 2006.
2. M. V. Schanz, "Commanding Control," *Air Force Magazine*, pp. 42–50, nov 2014.
3. U.S. Department of Defense, "Quadrennial Defense Review Report," 2014.
4. A. Butler, "Pentagon's 'Combat Cloud' Concept Taking Shape," 2014.
5. R. Laird, "Why Air Force Needs Lots Of F-35s : Gen . Hostage On The ' Combat Cloud '," 2013.
6. J. S. Chow and N. R. Sandell, "USAF Scientific Advisory Board Study Airborne Networking and Communications for Contested Environments Study Abstract," tech. rep., 2013.
7. R. S. Deakin, *Battlespace Technologies: Network-Enabled Information Dominance*. The Artech House intelligence and information operations series, Artech House, Incorporated, 2010.
8. R. Ramanathan, "On the performance of ad hoc networks with beamforming antennas," *Proceedings of the 2nd ACM international symposium on Mobile ad hoc networking & computing - MobiHoc '01*, pp. 95–105, 2001.
9. C. Cirullo, R. Olsen, C. Meagher, R. Ferro, J. Yu, and N. Stevens, "A solution to network protocol issues for directional ad-hoc networks through topology control and a multiple-radio-per-node architecture," *Proceedings - IEEE Military Communications Conference MILCOM*, pp. 1085–1089, 2011.

10. S. Milner, J. Llorca, and C. Davis, "Autonomous Reconfiguration and Control In Directional Mobile Ad Hoc Networks," *Circuits and Systems Magazine, IEEE*, vol. 9, no. 2, pp. 10–26, 2009.
11. R. Ramanathan and R. Rosales-Hain, "Topology Control of Multihop Wireless Networks using Transmit Power Adjustment," *Proceedings IEEE INFOCOM 2000*, vol. 2, 2000.
12. B. Ramamurthy, W. G. Cowley, L. M. Davis, and G. Bolding, "On MIMO SATCOM Capacity Analysis : Utilising Polarization and Spatial Multiplexing," *Proceedings - IEEE Military Communications Conference MILCOM*, no. 1, pp. 163–168, 2015.
13. S. Sangodoyin, S. Member, V. Kristem, S. Member, C. U. Bas, S. Member, J. Lee, S. Member, C. Schneider, G. Sommerkorn, J. Zhang, S. Member, and R. Thom, "Cluster-based Analysis of 3D MIMO Channel Measurement in an Urban Environment," *Proceedings - IEEE Military Communications Conference MILCOM*, pp. 765–770, 2015.
14. D. Piazza and U. Spagnolini, "Spatial Multiplexing," 2013.
15. M. A. S. Natera, A. García-aguilar, J. Mora-cuevas, J.-m. F. González, P. Padilla, D. Torre, J. G.-g. Trujillo, R. M. Rodríguez-osorio, M. S. Pérez, L. D. H. Ariet, and M. S. Castañer, *New Antenna Array Architectures for Satellite Communications*. 2010.
16. "MIMO & 802.11ac: Challenge or Opportunity?," 2014.
17. B. N. Cheng, R. Charland, P. Christensen, L. Veytser, and J. Wheeler, "Evaluation of a multihop airborne ip backbone with heterogeneous radio technologies," *IEEE Transactions on Mobile Computing*, vol. 13, no. 2, pp. 299–310, 2014.

18. H. Chen and K. Shi, "Topology control for predictable delay-tolerant networks based on probability," *Ad Hoc Networks*, vol. 24, pp. 147–159, 2015.
19. E. Çetinkaya and J. Rohrer, "Protocols for highly-dynamic airborne networks," *MobiCom'12*, pp. 411–413, 2012.
20. D. J. Van Hook, M. O. Yeager, and J. D. Laird, "Automated Topology Control For Wideband Directional Links In Airborne Military Networks," *IEEE Military Communications Conference (MILCOM)*, 2005.
21. O. D. Incel, "A survey on multi-channel communication in wireless sensor networks," *Computer Networks*, vol. 55, no. 13, pp. 3081–3099, 2011.
22. E. Baskaran, J. Llorca, S. D. Milner, and C. C. Davis, "Topology reconfiguration with successive approximations," *Proceedings - IEEE Military Communications Conference MILCOM*, pp. 1–7, 2007.
23. P. Santi, *Topology Control in Wireless Ad Hoc and Sensor Networks*. John Wiley & Sons, Ltd, 2005.
24. N. Grumman, *Understanding Voice and Data Link Networking: Northrop Grumman's Guide to Secure Tactical Data Links*. No. 135-02-005, Grumman, Northrop, 2014.
25. N. Grumman, *Understanding TADIL Planning and Operations: A Guidebook for Operators, Planners, and Managers*. Logicon, Incorporated, 2000.
26. A. Grilo, M. Macedo, P. Sebastião, and M. Nunes, "Electronic protection and routing optimization of MANETs operating in an electronic warfare environment," *Ad Hoc Networks*, vol. 5, pp. 1031–1045, 2007.

27. J. Yuan, Zongpeng Li, Wei Yu, and Baochun Li, "A Cross-Layer Optimization Framework for Multihop Multicast in Wireless Mesh Networks," *IEEE Journal on Selected Areas in Communications*, vol. 24, no. 11, pp. 2092–2103, 2006.
28. S. Siraj, A. K. Gupta, and Badgajar-Rinku, "Network Simulation Tools Survey," *International Journal of Advanced Research in Computer and Communication Engineering Vol. 1, Issue 4, June 2012*, vol. 1, no. 4, pp. 201–210, 2012.
29. J. P. G. Sterbenz, "Network Simulation with ns-3," *Simulation*, no. March, pp. 1–15, 2010.
30. E. Weingärtner, H. vom Lehn, and K. Wehrle, "A Performance Comparison of Recent Network Simulators," *Communications. 2009 IEEE International Conference on*, pp. 1–5, 2009.
31. S. J. Mason, R. R. Hill, L. Mönch, O. Rose, T. Jefferson, J. W. Fowler, S. H. Kurkowski, S. R. Graham, K. M. Hopkinson, R. W. Thomas, and J. W. Abernathy, "Research and Analysis of Simulation-based Networks through Multi-Objective Visualization1," *Proceedings of the 2008 Winter Simulation Conference*, p. 10, 2008.
32. D. Garc and A. Group, "Présentation d ' OMNET ++ INTRODUCTION TO SIMULATION WITH OMNET +," tech. rep., 2007.
33. A. Varga and R. Hornig, "An Overview of the OMNeT++ Simulation Environment," *Proceedings of the 1st International Conference on Simulation Tools and Techniques for Communications, Networks and Systems & Workshops*, pp. 60:1—60:10, 2008.
34. L. Hogie, P. Bouvry, and F. Guinand, "An Overview of MANETs Simulation,"

Electronic Notes in Theoretical Computer Science, vol. 150, no. 1, pp. 81–101, 2006.

35. A. Varga, “The OMNeT++ Discrete Event Simulation System,” *Proceedings of the European Simulation Multiconference*, pp. 319–324, 2001.
36. A. Varga, “OMNeT++ Discrete Event Simulator - What is OMNeT++.”
37. Ó. Helgason and S. T. Kouyoumdjieva, “Enabling Multiple Controllable Radios in OMNeT ++ Nodes,” *Design*, 2011.
38. A. A. Giordano and A. H. Levesque, *Modeling of Digital Communication Systems Using SIMULINK*. John Wiley & Sons, 2015.
39. G. E. P. Box, “Quantum Diaries.”
40. J. P. Rohrer, E. K. Çetinkaya, H. Narra, D. Broyles, K. Peters, and J. P. G. Sterbenz, “AeroRP performance in highly-dynamic airborne networks using 3D Gauss-Markov mobility model,” *Proceedings - IEEE Military Communications Conference MILCOM*, pp. 834–841, 2011.
41. M. L. Sichitiu, “Mobility Models for Ad Hoc Networks,” *Guide to Wireless Ad Hoc Networks*, p. 237, 2009.
42. N. Aschenbruck and E. Gerhards-Padilla, “A survey on mobility models for performance analysis in tactical mobile networks,” *Journal of Telecommunications and Information Technology*, vol. 2, pp. 54—61, 2008.
43. F. Bai and A. Helmy, “A Survey of Mobility Models in Wireless Adhoc Networks,” *Wireless Ad Hoc and Sensor Networks*, pp. 1–30, 2004.

44. O. K. Sahingoz, "Mobile networking with UAVs: Opportunities and challenges," *2013 International Conference on Unmanned Aircraft Systems, ICUAS 2013 - Conference Proceedings*, pp. 933–941, 2013.
45. B. N. Cheng, A. Coyle, S. McGarry, I. Pedan, L. Veytser, and J. Wheeler, "Characterizing routing with radio-to-router information in a heterogeneous airborne network," *IEEE Transactions on Wireless Communications*, vol. 12, no. 8, pp. 4183–4195, 2013.
46. J. N. Wang, J. V. Hook, and P. Deutsch, "Inter-domain Routing for Military Mobile Networks," *Proceedings - IEEE Military Communications Conference MILCOM*, pp. 407–412, 2015.
47. J. Harms and R. Holte, "Impact of lossy links on performance of multihop wireless networks," *24*, pp. 303–308, 2005.
48. J. M. M. Kamal, M. S. Hasan, A. L. Griffiths, and H. Yu, "Development and verification of simulation model based on real MANET experiments for transport layer protocols (UDP and TCP)," *International Journal of Automation and Computing*, vol. 10, no. 1, pp. 53–63, 2013.
49. P. Mohapatra and S. V. Krishnamurthy, "Ad hoc networks: Technologies and protocols," *Ad Hoc Networks: Technologies and Protocols*, pp. 1–270, 2005.
50. J. F. Kurose and K. W. Ross, *COMPUTER NETWORKING A Top-Down Approach*. Pearson, 2013.
51. J. Wang, P. Deutsch, A. Coyle, T. Shake, and B.-n. Cheng, "An Implementation of a Flexible Topology Management System for Aerial High Capacity Directional Networks," *Proceedings - IEEE Military Communications Conference MILCOM*, pp. 1018–1023, 2015.

52. R. Ramanathan, R. Allan, P. Basu, J. Feinberg, G. Jakllari, V. Kawadia, S. Loos, J. Redi, C. Santivanez, and J. Freebersyser, "Scalability of Mobile Ad Hoc Networks: Theory vs practice," *2010 - Milcom 2010 Military Communications Conference*, pp. 493–498, 2010.
53. T. Bosaw, "Modeling the Multifunction Advanced Data Link (MADL) SiS and MAC Layers in MATLAB Memo Number : 63M-09-59," Tech. Rep. August, 2010.
54. V. K. Ananth Grama, Anshul Gupta, George Karypis, *Introduction to Parallel Computing, Second Edition*, vol. 1. Addison Wesley, 2003.
55. T. Ulinskas, W. Golonka, and D. Duran, "On the Problem of Routing in Mobile Ad Hoc Wireless Networks with Directional Antennas," *Proceedings - IEEE Military Communications Conference MILCOM*, pp. 395–400, 2015.
56. M. A. Mahmood, W. K. Seah, and I. Welch, "Reliability in wireless sensor networks: A survey and challenges ahead," *Computer Networks*, vol. 79, pp. 166–187, 2015.
57. M. Younis, I. F. Senturk, K. Akkaya, S. Lee, and F. Senel, "Topology management techniques for tolerating node failures in wireless sensor networks: A survey," *Computer Networks*, vol. 58, no. 1, pp. 254–283, 2014.
58. S. Jeon, N. Kang, D. Corujo, and R. L. Aguiar, "Comprehensive performance evaluation of distributed and dynamic mobility routing strategy," *Computer Networks*, vol. 79, pp. 53–67, 2015.
59. A. Swidan, S. Khattab, Y. Abouelseoud, and H. Elkamchouchi, "A Secure Geographical Routing Protocol for Highly-Dynamic Aeronautical Networks," *Pro-*

- ceedings - IEEE Military Communications Conference MILCOM*, pp. 413–418, 2015.
60. A. Boukerche, B. Turgut, N. Aydin, and M. Ahmad, “Routing protocols in ad hoc networks: A survey,” *Computer Networks*, pp. 1–66, 2011.
61. S. Ade and P. Tijare, “Performance comparison of AODV, DSDV, OLSR and DSR routing protocols in mobile ad hoc networks,” *International Journal of Information Technology . . .*, vol. 2, no. 2, pp. 545–548, 2010.
62. R. L. Garner, *Heuristically driven search methods for topology*. PhD thesis, Air Force Institute of Technology, 2007.
63. S. Abid, M. Othman, and N. Shah, “3D P2P overlay over MANETs,” *Computer Networks*, vol. 64, pp. 89–111, 2014.
64. E. Hossain and K. K. Leung, *Wireless Mesh Networks*. Springer, 2007.
65. R. Annavaajjala, C. C. Yu, and J. M. Zagami, “Communication over Non-Gaussian Channels — Part I : Mutual Information and Optimum Signal Detection,” *Proceedings - IEEE Military Communications Conference MILCOM*, pp. 1159–1164, 2015.
66. L. Conceição and M. Curado, “Onto scalable wireless ad hoc networks: Adaptive and location-aware clustering,” *Ad Hoc Networks*, vol. 11, no. 8, pp. 2484–2499, 2013.
67. D. Tung, C. Wong, Q. Chen, and F. Chin, “Journal of Sensor Directional Medium Access Control (MAC) Protocols in Wireless Ad Hoc and Sensor Networks : A Survey,” *Journal of Sensor and Actuator Networks*, pp. 67–153, 2015.

68. G. Elmasry, B. Aanderud, W. Kraus, and R. McCabe, "Software-Defined Dynamic Power-Control and Directional-Reuse Protocol for TDMA Radios .," *Proceedings - IEEE Military Communications Conference MILCOM*, pp. 139–144, 2015.
69. Y. Zhou, Y. Fang, and M. Tanguay, "An Optimized Link Scheduling Technique for Mobile Ad Hoc Networks Using Directional Antennas," *Proceedings - IEEE Military Communications Conference MILCOM*, pp. 723–728, 2015.
70. S. Ponnaluri, S. Soltani, Y. Shi, and Y. Sagduyu, "Spectrum Efficient Communications with Multiuser MIMO , Multiuser Detection and Interference Alignment," *Proceedings - IEEE Military Communications Conference MILCOM*, pp. 1506–1511, 2015.
71. V. Van Son, P. T. Hiep, and R. Kohno, "Spatial Reuse TDMA/CDMA in Multi-hop MIMO Relay Systems with Imperfect CSI," *Wireless Personal Communications*, pp. 1–12, 2015.
72. L. Frenzel, *Principles of Electronic Communication systems*. McGraw-Hill, 2007.
73. I. Rhee and J. Lee, "Distributed Scalable TDMA Scheduling Algorithm," *Technical Report TR-2004-14*, 2004.
74. A. S. Tanenbaum and M. Van Steen, *Distributed Systems: Principles and Paradigms, 2/E*. Pearson Prentice Hall, 2007.
75. K. Rosen, *Discrete Mathematics and Its Applications*. McGraw-Hill, 2011.
76. J. Pattillo and S. Butenko, "Clique, independent set, and graph coloring," *Encyclopedia of Operations Research and Management Science*, pp. 3150–3163, 2011.

77. P. J. Nicholas and K. L. Hoffman, "Computational Challenges of Dynamic Channel Assignment for Military MANET," *Proceedings - IEEE Military Communications Conference MILCOM*, pp. 1183–1190, 2015.
78. H. B. Salameh and M. Krunz, "Distance- and Traffic-Aware Channel Assignment in Cognitive Radio Networks," *Proceedings - IEEE Communications Society*, 2008.
79. M. Gong and S. Midkiff, "Distributed channel assignment protocols: a cross-layer approach," *IEEE Wireless Communications and Networking Conference, 2005*, vol. 4, pp. 2195–2200, 2005.
80. F. Furini, V. Gabrel, and I.-c. Ternier, "An improved DSATUR-based Branch and Bound for the Vertex Coloring Problem State of the art : DSATUR-based Branch and Bound," *Optimization Online*, p. 22, 2015.
81. J. Culberson, "Graph Coloring Programs Manual A Note on the Source Code Structure," 2015.
82. S. Salhi, "Defining tabu list size and aspiration criterion within tabu search methods," *Computers & Operations Research*, vol. 29, no. 1, pp. 67–86, 2002.
83. A. Ghosh, O. D. Incel, V. S. A. Kumar, and B. Krishnamachari, "Multichannel Scheduling and Spanning Trees: Throughput–Delay Tradeoff for Fast Data Collection in Sensor Networks," *IEEE/ACM Transactions on Networking*, vol. 19, no. 6, pp. 1731–1744, 2011.
84. A. Cornejo, S. Viqar, and J. L. Welch, "Reliable neighbor discovery for mobile ad hoc networks," *Ad Hoc Networks*, vol. 12, no. 1, pp. 259–277, 2014.
85. G. Decandia, D. Hastorun, M. Jampani, G. Kakulapati, A. Lakshman, A. Pilchin, S. Sivasubramanian, P. Voshall, and W. Vogels, "Dynamo : Ama-

- zon's Highly Available Key-value Store," *October*, vol. 41, no. 6, pp. 205–220, 2007.
86. F. Z. Yousaf and C. Wietfeld, "Solving pinball routing, race condition and loop formation issues in nested mobile networks," *Computer Networks*, vol. 56, no. 4, pp. 1357–1375, 2012.
87. N. Mckeown, T. Anderson, H. Balakrishnan, G. M. Parulkar, L. L. Peterson, J. Rexford, S. Shenker, J. S. Turner, and S. Louis, "OpenFlow: enabling innovation in campus networks," *Computer Communication Review*, vol. 38, no. 2, pp. 69–74, 2008.
88. N. Foster, M. Freedman, and R. Harrison, "Frenetic: a high-level language for OpenFlow networks," *ACM PRESTO 2010*, p. 6, 2010.
89. T. T. Truong, K. N. Brown, and C. J. Sreenan, "Multi-objective hierarchical algorithms for restoring Wireless Sensor Network connectivity," *Ad Hoc Networks*, no. May, 2015.
90. M. Ghasemi, M. Abdolahi, M. Bag-Mohammadi, and A. Bohlooli, "Adaptive multi-flow opportunistic routing using learning automata," *Ad Hoc Networks*, vol. 25, pp. 472–479, 2015.
91. S. V. Muravyov, S. Tao, M. C. Chan, and E. V. Tarakanov, "Consensus rankings in prioritized converge-cast scheme for wireless sensor network," *Ad Hoc Networks*, vol. 24, pp. 160–171, 2015.
92. Y. Zhang, J. M. Ng, and C. P. Low, "A distributed group mobility adaptive clustering algorithm for mobile ad hoc networks," *Computer Communications*, vol. 32, no. 1, pp. 189–202, 2009.

93. A. A. Abbasi and M. Younis, "A survey on clustering algorithms for wireless sensor networks," *Computer Communications*, vol. 30, pp. 2826–2841, 2007.
94. I. I. Er and W. K. Seah, "Performance analysis of mobility-based d-hop (Mob-DHop) clustering algorithm for mobile ad hoc networks," *Computer Networks*, vol. 50, pp. 3375–3399, 2006.
95. X. Gao, B. Xu, and J. Li, "A distributed design for minimum 2-Connected m-Dominating Set in bidirectional wireless ad-hoc networks," *Tsinghua Science and Technology*, vol. 17, no. 5, pp. 553–566, 2012.
96. T. Camp, J. Boleng, and V. A. Davies, "A Survey of Mobility Models for Ad Hoc Network Research," *Wireless Communications & Mobile Computing (WCMC): Special issue on Mobile Ad Hoc Networking: Research, Trends and Applications*, vol. 2, no. 5, pp. 483–502, 2002.
97. G. Bounova and O. De Weck, "Overview of metrics and their correlation patterns for multiple-metric topology analysis on heterogeneous graph ensembles," *Physical Review E*, vol. 85, no. 1, p. 12, 2012.
98. D. Easley and J. Kleinberg, *Networks, crowds, and markets: Reasoning about a highly connected world*. Cambridge University Press, 2010.
99. T. J. Vitolo, J.-q. Hu, L. Servit, and V. Mehtat, "Topology Formulation Algorithms For Wireless Networks With Reconfigurable Directional Links," *IEEE Military Communications Conference (MILCOM)*, 2005.
100. Y. Wu, F. Wang, M. T. Thai, and Y. Li, "Constructing K-Connected M-Dominating Sets in Wireless Sensor Networks," *Proceedings of the 9th ACM international symposium on Mobile ad hoc networking and computing*, pp. 83–90, 2008.

101. D. Grigoras and M. Riordan, "Cost-effective mobile ad hoc networks management," *Future Generation Computer Systems*, vol. 23, pp. 990–996, 2007.
102. M. Caesar, M. Castro, E. Nightingale, G. O'Shea, and A. Rowstron, "Virtual ring routing: network routing inspired by DHTs," *SIGCOMM '06: Proceedings of the 2006 conference on Applications, technologies, architectures, and protocols for computer communications*, pp. 351–362, 2006.
103. L. Kant, J. Lee, G. Kim, and R. Miller, "Cross-layer Framework and Condition-based Topology Control for Contested," *Proceedings - IEEE Military Communications Conference MILCOM*, pp. 1030–1034, 2015.
104. A. Goldsmith, M. Effros, R. Koetter, M. Médard, A. Ozdaglar, and L. Zheng, "Beyond Shannon: The quest for fundamental performance limits of wireless ad hoc networks," *IEEE Communications Magazine*, vol. 49, no. May, pp. 195–205, 2011.
105. I. Bekmezci, O. K. Sahingoz, and a. Temel, "Flying Ad-Hoc Networks (FANETs): A survey," *Ad Hoc Networks*, vol. 11, no. 3, pp. 1254–1270, 2013.
106. S. Vakil and B. Liang, "Effect of Joint Cooperation and Multi-Hopping on the Capacity of Wireless Networks," *2008 5th Annual IEEE Communications Society Conference on Sensor, Mesh and Ad Hoc Communications and Networks*, vol. 1, pp. 100–108, 2008.
107. A. Fu, P. Sadeghi, and M. Medard, "Dynamic Rate Adaptation for Improved Throughput and Delay in Wireless Network Coded Broadcast," *IEEE 2013*, vol. 22, no. 6, p. 14, 2013.
108. H. Rahul, F. Edalat, D. Katabi, and C. C. G. Sodini, "Frequency-aware rate

adaptation and MAC protocols,” *International Conference on Mobile Computing and Networking*, pp. 193–204, 2009.

109. Q. Lin and M. A. Weitnauer, “SINR Analysis and Energy Allocation of Preamble and Training for Time Division CT with Range Extension,” *Proceedings - IEEE Military Communications Conference MILCOM*, pp. 1730–1735, 2015.

Vita

Major Geise has had multiple assignments related to airborne networking, which inspired his research topic interest. He first joined the Air Force as an enlisted airmen, and served as an F-16 avionics maintenance technician mastering integrated avionics diagnostic and test procedures. He then received his Bachelor of Science degree in Computer Engineering and commissioned through the ROTC program.

As a System Integration Engineer in the Joint Tactical Radio System (JTRS) program at Hanscom AFB, he led a 6-member team to develop waveforms for next-generation Software Defined Radios (SDRs).

As a Systems Engineering Branch Chief for the Multi-function Advanced Data Link (MADL) program at Hanscom AFB, he led a 12-member team working to extend the JSF low-probability of interference and detection (LPI/LPD) datalink capability to additional 5th generation low-observable platforms (F-22, B-2), with the objective of increasing net-centric C2ISR capabilities within the contested and anti-access battlespace.

As Flight Commander of the F-35 Effectiveness Test Flight at Edwards Air Force Base, he managed Operational Test (OT) readiness review of \$40M JSF modeling and simulation capability, which documented simulation fidelity and limitations.

As Chief of the Joint Strike Fighter (JSF) Operational Test Team (JOTT) Integrated Test Team Division at Edwards AFB he was responsible for \$12M in test analysis tool development.

In August of 2014 he entered the Graduate School of Engineering, Air Force Institute of Technology at Wright-Patterson AFB. Upon graduation he will be assigned to the Air Force Research Laboratory.

REPORT DOCUMENTATION PAGE

Form Approved
OMB No. 0704-0188

The public reporting burden for this collection of information is estimated to average 1 hour per response, including the time for reviewing instructions, searching existing data sources, gathering and maintaining the data needed, and completing and reviewing the collection of information. Send comments regarding this burden estimate or any other aspect of this collection of information, including suggestions for reducing this burden to Department of Defense, Washington Headquarters Services, Directorate for Information Operations and Reports (0704-0188), 1215 Jefferson Davis Highway, Suite 1204, Arlington, VA 22202-4302. Respondents should be aware that notwithstanding any other provision of law, no person shall be subject to any penalty for failing to comply with a collection of information if it does not display a currently valid OMB control number. **PLEASE DO NOT RETURN YOUR FORM TO THE ABOVE ADDRESS.**

1. REPORT DATE (DD-MM-YYYY) 03-24-2016		2. REPORT TYPE Master's Thesis		3. DATES COVERED (From — To) Sept 2015 — Mar 2016	
4. TITLE AND SUBTITLE Airborne Directional Networking: Topology Control Protocol Design				5a. CONTRACT NUMBER	
				5b. GRANT NUMBER	
				5c. PROGRAM ELEMENT NUMBER	
				5d. PROJECT NUMBER	
				5e. TASK NUMBER	
6. AUTHOR(S) Geise, Barry, C., Maj, USAF				5f. WORK UNIT NUMBER	
7. PERFORMING ORGANIZATION NAME(S) AND ADDRESS(ES) Air Force Institute of Technology Graduate School of Engineering and Management (AFIT/EN) 2950 Hobson Way WPAFB OH 45433-7765				8. PERFORMING ORGANIZATION REPORT NUMBER AFIT-ENG-MS-16-M-017	
intentionally left blank				10. SPONSOR/MONITOR'S ACRONYM(S)	
				11. SPONSOR/MONITOR'S REPORT NUMBER(S)	
12. DISTRIBUTION / AVAILABILITY STATEMENT DISTRIBUTION STATEMENT A: APPROVED FOR PUBLIC RELEASE; DISTRIBUTION UNLIMITED.					
13. SUPPLEMENTARY NOTES This material is declared a work of the U.S. Government and is not subject to copyright protection in the United States.					
14. ABSTRACT This research identifies and evaluates the impact of several architectural design choices in relation to airborne networking in contested environments related to autonomous topology control. Using simulation, we evaluate topology reconfiguration effectiveness using classical performance metrics for different point-to-point communication architectures. Our attention is focused on the design choices which have the greatest impact on reliability, scalability, and performance. In this work, we discuss the impact of several practical considerations of airborne networking in contested environments related to autonomous topology control modeling. Using simulation, we derive multiple classical performance metrics to evaluate topology reconfiguration effectiveness for different point-to-point communication architecture attributes for the purpose of qualifying protocol design elements.					
15. SUBJECT TERMS Autonomous topology control, ad-hoc, airborne directional networking, A2/AD, contested tactical environments					
16. SECURITY CLASSIFICATION OF:			17. LIMITATION OF ABSTRACT	18. NUMBER OF PAGES	19a. NAME OF RESPONSIBLE PERSON
a. REPORT	b. ABSTRACT	c. THIS PAGE			Douglas D. Hodson, PhD, AFIT/EN
U	U	U	UU	127	19b. TELEPHONE NUMBER (include area code) (937) 255-3636, x4719; douglas.hodson@afit.edu